

10-23-16

TABLE 7-202: OPEN SPACE DISTRICTS - PERMITTED AND CONDITIONAL USES

USES	DISTRICTS	USE STANDARDS
	OS	
<b>RESIDENTIAL USES</b>		
Dwelling, Caretaker	P	
<b>INSTITUTIONAL USES</b>		
Cultural Facility	CB	Subject to §14-308
Government Facilities – Offices: Park Related	P	
Government Facilities – Public Works	P	
Government Facilities – Non-Park	CO	
<b>OPEN SPACE &amp; AGRICULTURAL USES</b>		
Cemetery	CB	
Community-Managed Open-Space Farm	CB	Subject to §14-307
Community-Managed Open-Space Garden	P	Subject to §14-307
Fishing Pier	CB	
Forest and Nature Preserves	P	
Horse Stable	CB	
Marina: Recreational Marina	CB	Subject to §14-323
Parks and Playgrounds	P	
Urban Agriculture	CB	Subject to §14-339
Zoo	CB	
<b>COMMERCIAL USES</b>		
Country Club	P	
Driving Range	CB	
Fairground	CB	
Golf Course	CB	
Recreation: Indoor	CB	Subject to §14-312
Recreation: Outdoor	P	Subject to §14-312
Restaurant (Within Publicly-Owned Park)	CO <sup>6</sup>	
Restaurant General	C <sup>6</sup>	Subject to §14-3XX
<b>OTHER</b>		
Electric Substation: Enclosed	CB	Subject to §14-339
Electric Substation: Indoor	CB	Subject to §14-339
Parking Lot Accessory Only	CO	Subject to §14-331
Parking Structure Accessory Only	CO	Subject to §14-331
Telecommunications Facility	CB	Subject to §14-340
Utilities	CB	Subject to §14-339
Wireless Communications Service	CB, P <sup>1</sup>	

**TABLE 7-202 FOOTNOTES:**

<sup>1</sup> Only Wireless Communication Services that are modifications to – and do not substantially change the physical dimension of – an existing telecommunication facility, are considered permitted.

<sup>6</sup> All uses that do not engage in alcoholic Beverage sales can continue to operate in the manner listed in the tables. Any use that does not engage in alcoholic beverage sales must obtain a conditional use unless that type of use is not allowed in that particular district.



TABLE 7-203: OPEN SPACE DISTRICTS - BULK AND YARD REGULATIONS	
BULK & YARD REGULATIONS	DISTRICTS
	OS
<b>BULK REGULATIONS</b>	
<b>MINIMUM LOT AREA</b>	Cemetery: 2 ac All Other Uses: None
<b>MAXIMUM BUILDING HEIGHT</b>	Public Principal Structure: 50 feet Private Principal Structure 35 feet Private Accessory Structure is limited to both 20 feet and one story
<b>YARD REGULATIONS</b>	
<b>MINIMUM FRONT YARD</b>	20'
<b>MINIMUM INTERIOR SIDE YARD</b>	25'
<b>MINIMUM CORNER SIDE YARD</b>	20'
<b>MINIMUM REAR YARD</b>	25'



**TABLE 8-301: DETACHED AND SEMI-DETACHED RESIDENTIAL DISTRICTS - PERMITTED AND CONDITIONAL USES**

USES	DISTRICTS									USE STANDARDS
	R-1A	R-1B	R-1C	R-1D	R-1E	R-1	R-2	R-3	R-4	
<b>RESIDENTIAL USES</b>										
Day Care Home: Child or Adult	P	P	P	P	P	P	P	P	P	Subject to §14-310
Dwelling: Detached	P	P	P	P	P	P	P	P	P	
Dwelling: Semi-Detached							P		P	
Home Occupation	P	P	P	P	P	P	P	P	P	Subject to §15-507
Residential-Care Facility	P	P	P	P	P	P	P	P	P	Subject to §14-334(a)
<b>INSTITUTIONAL USES</b>										
Community Center	CB	CB	CB	CB	CB	CB	CB	CB	CB	
Cultural Facility	CB	CB	CB	CB	CB	CB	CB	CB	CB	Subject to §14-308
Educational Facility: Primary/Secondary	CB	CB	CB	CB	CB	CB	CB	CB	CB	
Educational Facility: Post-Secondary	CB	CB	CB	CB	CB	CB	CB	CB	CB	
Government Facilities	CB	CB	CB	CB	CB	CB	CB	CB	CB	
Place of Worship	CB	CB	CB	CB	CB	CB	CB	CB	CB	Subject to §14-332
<b>COMMERCIAL USES</b>										
Bed and Breakfast (up to 3 rooms)	CB	CB	CB	CB	CB	CB	CB	CB	CB	
Country Club	CB	CB	CB	CB	CB	CB	CB	CB	CB	
Day Care Center: Child or Adult	CB	CB	CB	CB	CB	CB	CB	CB	CB	Subject to §14-309
Lodge or Social Club	CB	CB	CB	CB	CB	CB	CB	CB	CB	
<b>OPEN SPACE USES</b>										
Community-Managed Open-Space Garden	P	P	P	P	P	P	P	P	P	Subject to §14-307
Community-Managed Open-Space Farm	CB	CB	CB	CB	CB	CB	CB	CB	CB	Subject to §14-307
Parks and Playgrounds	P	P	P	P	P	P	P	P	P	
Urban Agriculture	CB	CB	CB	CB	CB	CB	CB	CB	CB	Subject to §14-338
<b>OTHER</b>										
Alternative Energy Systems: Community Based	C, P <sup>1</sup>	C,P <sup>1</sup>	C,P <sup>1</sup>	C,P <sup>1</sup>	C,P <sup>1</sup>	C,P <sup>1</sup>	C,P <sup>1</sup>	C,P <sup>1</sup>	C,P <sup>1</sup>	Subject to §14-306
Electric Substation: Enclosed	CB	CB	CB	CB	CB	CB	CB	CB	CB	Subject to §14-339
Electric Substation: Indoor	CB	CB	CB	CB	CB	CB	CB	CB	CB	Subject to §14-339
Electric Substation: Outdoor	CB	CB	CB	CB	CB	CB	CB	CB	CB	Subject to §14-339
Telecommunications Facility	CB	CB	CB	CB	CB	CB	CB	CB	CB	Subject to §14-340
Utilities	CB	CB	CB	CB	CB	CB	CB	CB	CB	Subject to §14-339
Wireless Communications Services	CB, P <sup>2</sup>	CB, P <sup>2</sup>	CB, P <sup>2</sup>	CB, P <sup>2</sup>	CB, P <sup>2</sup>	CB, P <sup>2</sup>	CB, P <sup>2</sup>	CB, P <sup>2</sup>	CB, P <sup>2</sup>	

**TABLE 8-301 FOOTNOTES:**

<sup>1</sup> Alternative Energy Systems: Community Based are conditional on lots under 0.5 acre in lot area and permitted on lots of 0.5 acres or more in lot area.

<sup>2</sup> Only Wireless Communication Services that are modifications to – and do not substantially change the physical dimension of – an existing telecommunication facility, are considered permitted.



TABLE 8-401: DETACHED AND SEMI-DETACHED RESIDENTIAL DISTRICTS - BULK AND YARD REGULATIONS

**LEGEND:**

*D-D = Detached - Dwelling*

*D-SD = Semi-Detached - Dwelling*

BULK AND YARD STANDARDS	DISTRICTS									
	R-1A	R-1B	R-1C	R-1D	R-1E	R-1	R-2	R-3	R-4	
<b>BULK REGULATION</b>										
<b>MINIMUM LOT AREA</b>	2 ac	Dwelling: 1 ac/du Parks & Community Gardens: None Non-Residential: 1 ac	Dwelling: 21,780sf/du Parks & Community Gardens: None Non-Residential: 20,000sf	Dwelling: 14,520sf/du Parks & Community Gardens: None Non-Residential: 20,000sf	Dwelling: 9,000sf/du Parks & Community Gardens: None Non-Residential: 20,000sf	Dwelling: 7,300sf/du Parks & Community Gardens: None Non-Residential: 20,000sf	Dwelling: 5,000sf/du Parks & Community Gardens: None Non-Residential: 20,000sf	Dwelling: 5,000sf/du Parks & Community Gardens: None Non-Residential: 5,000sf	Dwelling: 3,000sf/du Parks & Community Gardens: None Non-Residential: 3,000sf	
<b>MINIMUM LOT WIDTH</b>	100'	75'	75'	60'	60'	50'	D-SD: 30' All Other Uses: 50'	45'	D-SD: 30' All Other Uses: 45'	
<b>MAXIMUM BUILDING HEIGHT</b>	35'	35'	35'	35'	35'	35'	35'	35'	35'	
<b>MAXIMUM LOT COVERAGE</b>	25%	25%	25%	25%	25%	30%	30%	35%	35%	
<b>MAXIMUM IMPERVIOUS SURFACE</b>	40%	40%	40%	40%	40%	50%	50%	50%	50%	





	R-1A	R-1B	R-1C	R-1D	R-1E	R-1	R-2	R-3	R-4
<b>FRONT YARD</b>	<p>Where 50% or more of lots on the blockface have been developed, the lesser of 40' or the average of front yard depth of the front yards of the improved lots</p> <p>Where less than 50% of lots on the blockface have been developed: 40'</p>								
<b>INTERIOR SIDE YARD<sup>1</sup></b>	20'	20'	15'	15'	10'	10'	D-D: 10' D-SD: 15' Non-Residential: 15'	10'	D-D: 10' D-SD: 15' Non-Residential: 15'
<b>CORNER SIDE YARD</b>	25'	25'	20'	20'	20'	20'	20'	20'	20'
<b>REAR YARD</b>	40'	40'	40'	30'	30'	30'	30'	25'	25'

**TABLE 8-401 FOOTNOTES:**

<sup>1</sup>For semi-detached dwellings, interior side yards are required only along the interior side lot line where the party wall between dwellings is not located.



TABLE 9-301: ROWHOUSE AND MULTI-FAMILY RESIDENTIAL DISTRICTS - PERMITTED AND CONDITIONAL USES

USES	DISTRICTS						USE STANDARDS
	R-5	R-6	R-7	R-8	R-9	R-10	
<b>RESIDENTIAL USES</b>							
Day Care Home: Child or Adult	P	P	P	P	P	P	Subject to §14-310
Dwelling: Detached	P	P	P	P	P	CB	
Dwelling: Semi-Detached	P	P	P	P	P	CB	
Dwelling: Rowhouse	P	P	P	P	P	P	
Dwelling, Multi-Family	P	P	P	P	P	P	Subject to §14-327
Fraternity or Sorority House					CO	CO	Subject to §14-313
Home Occupation	P	P	P	P	P	P	Subject to §15-507
Residential-Care Facility	P	P	P	P	P	P	Subject to §14-333
Residential-Care Facility, 17 or greater	CB	CB	CB	CB	CB	CB	
Rooming House: 10 or Less Units				CB	CB	CB	
Rooming House: 11 or More Units					CB	CB	
<b>INSTITUTIONAL USES</b>							
Community Center	CB	CB	CB	CB	CB	CB	
Cultural Facility	CB	CB	CB	CB	CB	CB	Subject to §14-308
Educational Facility: Primary and secondary	P	P	P	P	P	P	
Educational Facility: Post-Secondary	CB	CB	CB	CB	CB	CB	
Government Facilities - Offices	CB	CB	CB	CB	CB	CB	
Government Facilities: Public Works <sup>3</sup>	CB	CB	CB	CB	CB	CB	
Hospital	CB	CB	CB	CB	CB	CB	
Place of Worship	P	P	P	P	P	P	Subject to §14-332
<b>COMMERCIAL USES</b>							
Bed and Breakfast							
Day Care Center, Child or Adult	CB	CB	CB	CB	CB	CB	Subject to §14-309
Lodge or Social Club	CB	CB	CB	CB	CB	CB	Subject to §14-320
Neighborhood Commercial Establishment	CB	CB	CB	CB	CB	CB	Subject to §14-328
<b>OPEN SPACE USES</b>							
Community-Managed Open-Space Farm	CB	CB	CB	CB	CB	CB	Subject to §14-307
Community-Managed Open-Space Garden	P	P	P	P	P	P	Subject to §14-307
Parks and Playgrounds	P	P	P	P	P	P	
Urban Agriculture	CB	CB	CB	CB	CB	CB	Subject to §14-338
<b>OTHER</b>							
Alternative Energy Systems: Community-Based	CB, P <sup>1</sup>	CB, P <sup>1</sup>	CB, P <sup>1</sup>	CB, P <sup>1</sup>	CB, P <sup>1</sup>	CB, P <sup>1</sup>	Subject to §14-306
Electric Substation: Enclosed	CB	CB	CB	CB	CB	CB	Subject to §14-339
Electric Substation: Indoor	CB	CB	CB	CB	CB	CB	Subject to §14-339
Electric Substation: Outdoor	CB	CB	CB	CB	CB	CB	Subject to §14-339
Parking Lot (Principal Use)	CO	CO	CO	CO	CO	CO	Subject to §14-331
Parking Structure (Principal Use)	CO	CO	CO	CO	CO	CO	Subject to §14-331
Telecommunications Facility	CB	CB	CB	CB	CB	CB	Subject to §14-340
Utilities	CB	CB	CB	CB	CB	CB	Subject to §14-339
Wireless Communications Services	CB, P <sup>2</sup>	CB, P <sup>2</sup>	CB, P <sup>2</sup>	CB, P <sup>2</sup>	CB, P <sup>2</sup>	CB, P <sup>2</sup>	

**TABLE 9-301 FOOTNOTES:**

<sup>1</sup> Community-based alternative energy-generating systems are conditional on lots under 0.5 acre in lot area and permitted on lots of 0.5 acre or more in lot area.

<sup>2</sup> Only Wireless Communication Services that are modifications to – and do not substantially change the physical dimension of – an existing telecommunication facility, are considered permitted.

<sup>3</sup> In these zoning districts, 'Government Facilities: Public Works' only pertain to water, wastewater, and stormwater systems.



TABLE 9-401: ROWHOUSE AND MULTI-FAMILY RESIDENTIAL DISTRICTS - BULK AND YARD REGULATIONS

**LEGEND:**  
 D-D = Detached Dwelling  
 SD-D = Semi-Detached Dwelling  
 R = Rowhouse  
 MF = Multi-Family

		DISTRICTS					
		R-5	R-6	R-7	R-8	R-9	R-10
<b>BULK REGULATION</b>							
<b>MINIMUM LOT AREA</b>		D-D: 3,000sf/du D-SD: 2,500sf/du R: 2,500sf/du MF: 2,500sf/du MF - Age Restricted Housing <sup>2</sup> : 1,875sf/du Residential Care Facility for Elderly <sup>2</sup> : 750sf/du Parks & Community-Managed Open Space: None Non-Residential: 3,000sf <sup>4</sup>	D-D: 3,000sf/du D-SD: 2,000sf/du R: 1,500sf/du MF: 1,500sf/du MF - Age Restricted Housing <sup>2</sup> : 1,125sf/du Residential Care Facility for Elderly <sup>2</sup> : 550sf/du Parks & Community-Managed Open Space: None Non-Residential: 3,000sf <sup>4</sup>	D-D: 3,000sf/du D-SD: 2,000sf/du R: 1,100sf/du MF: 1,100sf/du MF - Age Restricted Housing <sup>2</sup> : 825sf/du Residential Care Facility for Elderly <sup>2</sup> : 370sf/du Parks & Community-Managed Open Space: None Non-Residential: 3,000sf <sup>4</sup>	D-D: 3,000sf/du D-SD: 2,000sf/du R: 750sf/du MF: 750sf/du MF - Age Restricted Housing <sup>2</sup> : 575sf/du MF - Residential Care Facility for Elderly <sup>2</sup> : 245sf/du Parks & Community-Managed Open Space: None Non-Residential: 3,000sf <sup>4</sup>	D-D: 3,000sf/du D-SD: 2,500sf/du R: 750sf/du MF: 550sf/du Residential Care Facility for Elderly <sup>2</sup> : 200sf/du Parks & Community-Managed Open Space: None Non-Residential: 3,000sf <sup>4</sup>	D-D: 3,000sf/du D-SD: 2,000sf/du R: 500sf/du MF: 200sf/du Residential Care Facility for Elderly <sup>2</sup> : 120sf/du Parks & Community-Managed Open Space: None Non-Residential: 3,000sf
<b>MAXIMUM BUILDING HEIGHT</b>		D-D, D-SD & R: 35' MF & Non-Residential: Interior Lot: 35' Corner Lot <sup>3</sup> : 45'	D-D, D-SD & R: 35' MF & Non-Residential: Interior Lot: 35' Corner Lot <sup>3</sup> : 45'	D-D, D-SD & R: 35' MF & Non-Residential: Interior Lot: 35' Corner Lot <sup>3</sup> : 45'	D-D & D-SD: 35' R: 35'; Where ROW is more than 30' in width <sup>3</sup> , up to 45' is permitted by conditional use MF & Non-Residential: Interior Lot: 45' Corner Lot <sup>3</sup> : 60' is permitted by conditional use	D-D & D-SD: 35' R: 35'; Where ROW is more than 30' in width <sup>3</sup> , up to 45' is permitted by conditional use MF: Determined by FAR of 3.0 Non-Residential: 45'	D-D & D-SD: 35' R: 35'; Where ROW is more than 30' in width <sup>3</sup> , up to 45' is permitted by conditional use MF: Determined by FAR of 6.0 Non-Residential: 45'
<b>MAXIMUM LOT COVERAGE</b>		D-D & D-SD: 35% R: 40% MF: 40%	D-D & D-SD: 35% R: 45% MF: 45%	D-D & D-SD: 35% R: 50% MF: 70%	D-D & D-SD: 35% R: 60% for lots greater than 80 feet	D-D & D-SD: 35% R: 40% MF: 40%	D-D & D-SD: 35% R: 80% MF: 80%



**TABLE 9-401: ROWHOUSE AND MULTI-FAMILY RESIDENTIAL DISTRICTS - BULK AND YARD REGULATIONS**

**LEGEND:**  
 D-D = Detached Dwelling  
 SD-D = Semi-Detached Dwelling  
 R = Rowhouse  
 MF = Multi-Family

		DISTRICTS					
		R-5	R-6	R-7	R-8	R-9	R-10
		Non-Residential: 40%	Non-Residential: 40%	Non-Residential: 70%	80% for lots less than 80 feet. MF: 80% Non-Residential: 70%	Non-Residential: 40%	Non-Residential: 70%
<b>D-D &amp; D-SD:</b>	<b>MAXIMUM IMPERVIOUS SURFACE</b>	60%	60%	60%	60%	60%	60%
<b>R:</b>	<b>MAXIMUM IMPERVIOUS SURFACE OF REAR YARD</b>	65%	65%	65%	65%	65%	65%
<b>MINIMUM YARD REQUIREMENTS</b>							
<b>D-D &amp; D-SD:</b>	<b>FRONT YARD</b>	The average of front yard depth of the front yards of the improved lots on the blockface or 25', whichever is less	The average of front yard depth of the front yards of the improved lots on the blockface or 20', whichever is less	The average of front yard depth of the front yards of the improved lots on the blockface or 20', whichever is less	The average of front yard depth of the front yards of the improved lots on the blockface or 20', whichever is less	The average of front yard depth of the front yards of the improved lots on the blockface or 40', whichever is less	The average of front yard depth of the front yards of the improved lots on the blockface or 20', whichever is less
<b>R, MF &amp; NON-RESIDENTIAL:</b>	<b>FRONT YARD</b>	25'	20'	10'	None	R: 25' MF - Based on building height in stories: Up to 6 stories: 45' 7 or more stories: 65' MF front yards may be reduced for courtyard building design – Subject to §9-403	None





**TABLE 9-401: ROWHOUSE AND MULTI-FAMILY RESIDENTIAL DISTRICTS - BULK AND YARD REGULATIONS**

**LEGEND:**  
 D-D = Detached Dwelling  
 SD-D = Semi-Detached Dwelling  
 R = Rowhouse  
 MF = Multi-Family

	DISTRICTS					
	R-5	R-6	R-7	R-8	R-9	R-10
<b>INTERIOR SIDE YARD<sup>1</sup></b>	D-D: 10' D-SD: 15' R: None MF: 15' Non-Residential: 15'	D-D: 10' D-SD: 15' R: None MF: 15' Non-Residential: 15'	D-D & D-SD: 10' R: None MF: 10' Non-Residential: 15'	D-D & D-SD: 10' R: None MF: 10' Non-Residential: 10'	D-D & D-SD: 10' R: None MF: 10' Non-Residential: 10'	D-D & D-SD: 10' R: None MF: 10' Non-Residential: 10'
<b>CORNER SIDE YARD</b>	20'	20'	15'	D-D & D-SD: 15' R: None MF: 15' Non-Residential: 15'	D-D & D-SD: 15' R: None MF: 25' Non-Residential: 15'	D-D & D-SD: 15' R: None MF: 15' Non-Residential: 15'
<b>REAR YARD</b>	25'	25'	25'	D-D & D-SD: 25' R: 20' MF: 25' Non-Residential: 25'	10'	10'

**TABLE 9-401 FOOTNOTES:**

- <sup>1</sup>For semi-detached dwellings, interior side yards are required only along the interior side lot line where the party wall between dwellings is not located.
- <sup>2</sup>Where Table 9-401 does not indicate a separate standard for age-restricted housing or residential care facilities for the elderly, the multi-family standards apply.
- <sup>3</sup>Where additional height is allowed for corner lots, both rights-of-way must be 30' or more in width. Where additional height is allowed adjacent to a right-of-way 30' or more in width, both rights-of-way in the case of a corner lot must meet that requirement.
- <sup>4</sup>BMZA can waive minimum lot area for Neighborhood Commercial Conditional Use.



**TABLE 10-301: COMMERCIAL DISTRICTS - PERMITTED AND CONDITIONAL USES**

USES	DISTRICTS							USE STANDARDS
	C-1	C-1VC	C-1-E	C-2	C-3	C-4	C-5	
<b>RESIDENTIAL USES</b>								
Dwelling, Above the Ground Floor	P	P	P	P	P	CB	P	
Dwelling, Multi-Family	P	CB	P	P	P		P	Subject to §14-327
Day Care Home – Child or Adult	P	P	P	P	P		P	Subject to §14-310
Dwelling: Rowhouse	P	P	P	CB	CB		P	
Dormitory							P	
Fraternity and Sorority	CO	CO	CO	CO	CO		CO	
Live/Work Dwelling	P	P	P	P	P	CB	P	
Residential Care Facility	P	P	P	P	P		P	Subject to §14-334
Licensed Residential Care Facility, 17 or larger	CO	CO	CO	CO	CB		CB	
Rooming House,	CB	CB	CB	CB	CB		CB	
<b>INSTITUTIONAL USES</b>								
Community Center	CB	CB	CB	CB	P		P	
Cultural Facility	CB	CB	CB	CB	P		P	Subject to §14-308
Educational Facility: Primary/Secondary	CB	CB	CB	CB	CB		P	
Educational Facility: Commercial/Vocational				CB	P	P	P	
Educational Facility: Post-Secondary	CB	CB	CB	P	P	P	P	
Government Facilities - Public Works	CB <sup>4</sup>	CB <sup>4</sup>	CB <sup>4</sup>	CB	CB	CB	CB <sup>4</sup>	
Homeless Shelter					CB	CB	CB	
Hospital				CB	CB	CB	P	
Place of Worship	P	P	P	P	P	P	P	Subject to §14-332
<b>OPEN SPACE AND AGRICULTURAL USES</b>								
Community-Managed Open-Space Farm	CB	CB	CB	CB	CB	CB	CB	Subject to §14-307
Community-Managed Open-Space Garden	P	P	P	P	P	P	P	Subject to §14-307
Parks and Playgrounds –	P	P	P	P	P	P	P	
Marina: Dry Storage				CB	CB	P		Subject to §14-323
Marina: Recreational				CB	CB	P	P	Subject to §14-323
Urban Agriculture	CB	CB	CB	CB	CB	CB	CB	Subject to §14-339
<b>COMMERCIAL USES</b>								
Animal Clinic	P	P	P	P	P	P	P	
Art Gallery	P	P	P	P	P		P	
Arts Studio	P	P	P	P	P	P	P	
Arts Studio - Industrial				CB	CB	P	CB	
Bail Bonds Establishment			CO	CO	CO	CO	CO	
Banquet Hall				CO	CB	CB	P	
Body Art Establishment	CB	CB	CB	P	P	P	P	
Broadcasting Station (TV or Radio)				CB	P	P	P	
Car Wash – Outdoor					CB	P		Subject to §14-304
Car Wash – Fully Enclosed Structure					P	P	CB	Subject to §14-304
Carry-Out	CB	CB	CB	P	P	P	P	
Check Cashing Establishment	CO	CO	CO	CO	CO	CB	CB	
Convention Center							P	
Day Care Center, Child or Adult	CB	CB	CB	P	P	P	P	Subject to §14-309
Drive-Through Facility				CB	CB	CB		Subject to §14-311
Entertainment: Indoor	CB	CB	P	P	P	P	P	Subject to §14-312
Entertainment: Live (Standalone Establishment)			P		P	P	P	Subject to §14-319
Entertainment : Live– Secondary to Restaurant, Tavern, Art Studio or Art Gallery	CB	CB	P	CB	P	P	P	Subject to §14-319
Financial Institution	P	P	P	P	P	P	P	
Food Processing, Light	CB	CB	CB	CB	CB	CB	CB	



**TABLE 10-301: COMMERCIAL DISTRICTS - PERMITTED AND CONDITIONAL USES**

USES	DISTRICTS							USE STANDARDS
	C-1	C-1VC	C-1-E	C-2	C-3	C-4	C-5	
Funeral Home				CB	P	P		
Gas Station				CB	CB	P		Subject to §14-314
Greenhouse/Nursery	P	P	P	P	P	P	CB	
Heavy Retail, Rental and Service					CB	P		
Health Center	P	P	P	P	P	P	P	
Hotel/Motel	CB	CB	CB	P	P	P	P	
Kennel					CB	P	CB	Subject to §14-317
Lodge or Social Club	CB	CB	CB	CB	P	P	P	Subject to §14-320
Medical/Dental Clinic	CB	CB	CB	P	P	P	P	
Motor Vehicle Dealership – Fully Enclosed Structure				P	P	P	P	Subject to §14-325
Motor Vehicle Dealership – With Outdoor Display					CB	P		Subject to §14-325
Motor Vehicle Rental Establishment – Fully Enclosed Structure	P			P	P	P	P	Subject to §14-325
Motor Vehicle Rental Establishment – With Outdoor Display					CB	P		Subject to §14-325
Motor Vehicle Service and Repair, Major						P		Subject to §14-326
Motor Vehicle Service and Repair, Minor – Fully Enclosed Structure				P	P	P	P	Subject to §14-326
Motor Vehicle Service and Repair, Minor – With Outdoor Storage of Vehicles				CB	P	P		Subject to §14-326
Office	P	P	P	P	P	P	P	
Outdoor Dining	P	P	P	P	P	P	P	Subject to §14-329
Pawn Shop				CB	CB	CB	CB	
Personal Services Establishment	P	P	P	P	P	P	P	
Racetrack						CB		
Recreation: Indoor				P	P	P	P	Subject to §14-312
Recreation: Outdoor				CB	CB	CB	CB	Subject to §14-312
Recreational Vehicle Dealership					CB	P		
Restaurant	P <sup>6</sup>	CB <sup>6</sup>	P <sup>6</sup>	P <sup>6</sup>	P <sup>6</sup>	P <sup>6</sup>	P <sup>6</sup>	
Restaurant General	C <sup>6</sup>	C <sup>6</sup>	C <sup>6</sup>	C <sup>6</sup>	C <sup>6</sup>	C <sup>6</sup>	C <sup>6</sup>	Subject to §14-3XX
Restaurant Limited	P <sup>6</sup>	P <sup>6</sup>	P <sup>6</sup>	P <sup>6</sup>	P <sup>6</sup>	P <sup>6</sup>	P <sup>6</sup>	Subject to §14-3XX
Retail: Big Box Establishment					CB	CB	CB	Subject to §14-3XX
Retail Goods Establishment – No Alcoholic Beverages Sales	P	P	P	P	P	P	P	
Retail Goods Establishment – With Alcoholic Beverages Sales	CO <sup>6</sup>	CO <sup>6</sup>	CO <sup>6</sup>	CO <sup>6</sup>	CO <sup>6</sup>	P <sup>6</sup>	P <sup>6</sup>	Subject to §14-335
Stadium						CB	CB	
Tavern	CB <sup>6</sup>	CB <sup>6</sup>	P <sup>6</sup>	P <sup>6</sup>	P <sup>6</sup>	P <sup>6</sup>	P <sup>6</sup>	
Video Lottery Facility				P			P	
<b>INDUSTRIAL USES</b>								
Heliport							CB	
Industrial, Light						P		
Mini-Warehouse					CB	P	C <sup>1</sup>	
Motor Vehicle Operations Facility						P		
Movie Studio						P	P	
Printing Establishment				P	P	P	P	
Research and Development							P	
Truck Stop						C		
<b>OTHER</b>								
Alternative Energy System : Community-Based	P	P	P	P	P	P	P	Subject to §14-306
Electric Substation: Enclosed	CB	CB	CB	CB	CB	CB	CB	Subject to §14-339



**TABLE 10-301: COMMERCIAL DISTRICTS - PERMITTED AND CONDITIONAL USES**

USES	DISTRICTS							USE STANDARDS
	C-1	C-1VC	C-1-E	C-2	C-3	C-4	C-5	
Electric Substation: Indoor	CB	CB	CB	CB	CB	CB	CB	Subject to §14-339
Electric Substation: Outdoor	CB	CB	CB	CB	CB	CB	CB	Subject to §14-339
Parking Lot (Principal Use)	CB	CB	CB	CB	P	P	CO	Subject to §14-331
Parking Structure (Principal Use)				CB	P	P	CB	Subject to §14-331
Utilities	CB	CB	CB	CB	CB	CB	CB	Subject to §14-339
Telecommunications Facility	CB, p <sup>2</sup>	CB, p <sup>2</sup>	CB, p <sup>2</sup>	CB, p <sup>2</sup>	CB, p <sup>2</sup>	CB, p <sup>2</sup>	CB, p <sup>2</sup>	Subject to §14-340
Wireless Communications Service	CB,	CB	CB	CB	CB	CB	CB	

**TABLE 10-301 FOOTNOTES:**

- <sup>1</sup> Allowed only in an existing structure.
- <sup>2</sup> Only telecommunications base stations that comply with the stealth design standards of §14-339 are considered permitted uses.
- <sup>3</sup> Only Wireless Communication Services that are modifications to – and do not substantially change the physical dimension of – an existing telecommunication facility, are considered permitted.
- <sup>4</sup> In these zoning districts, 'Government Facilities: Public Works' only pertain to water, wastewater, and stormwater systems
- <sup>6</sup> All uses that do not engage in alcoholic Beverage sales can continue to operate in the manner listed in the tables. Any use that does not engage in alcoholic beverage sales must obtain a conditional use unless that type of use is not allowed in that particular district.





TABLE 10-401: COMMERCIAL ZONING DISTRICTS - BULK AND YARD REGULATIONS

BULK & YARD REGULATIONS	C-1	C-1-VC <sup>1</sup>	C-1-E	C-2	C-3	C-4
<b>BULK REGULATIONS</b>						
<b>MINIMUM LOT AREA</b>	Residential: 300 sf/du <u>Licensed Residential Care Facility for Elderly</u> ²: 200sf/du Other Uses: None	Residential: 5000 sf/du Elderly Housing efficiencies: 1500 sf/du Elderly Housing other: 2300 sf/du Rooming Units: 2500 sf/du Efficiencies: 3350 sf/du <u>Licensed Residential Care Facility for Elderly</u> ²: 200sf/du Other Uses: None	Residential: 550sf/du <u>Licensed Residential Care Facility for Elderly</u> ²: 200sf/du Other Uses: None	Residential: 225 sf/du <u>Licensed Residential Care Facility for Elderly</u> ²: 120sf/du Other Uses: None	Residential: 300sf/du <u>Licensed Residential Care Facility for Elderly</u> ²: 120sf/du Other Uses: None	Residential: 300sf/du <u>Licensed Residential Care Facility for Elderly</u> ²: 120sf/du Other Uses: None
<b>MAXIMUM LOT AREA</b>	<u>Non-Residential, Except Retail Goods Establishment</u> – Food Store: 10,000sf/establishment <u>Retail Goods Establishment</u> – Food Store: 20,000sf/establishment	<u>Non-Residential, Except Retail Goods Establishment</u> – Food Store: 2,000sf/establishment Restaurant: 4,000sf <u>Retail Goods Establishment</u> – Food Store: 15,000sf/establishment	<u>Non-Residential, Except Retail Goods Establishment</u> – Food Store: 10,000sf/establishment <u>Retail Goods Establishment</u> – Food Store: 20,000sf/establishment			
<b>MAXIMUM BUILDING HEIGHT</b>	<u>Non-Residential</u> : 40' <u>MF &amp; Mixed-Use with Dwellings Above the Ground Floor</u> : 60'	40'	<u>Non-Residential</u> : 40' <u>MF &amp; Mixed-Use with Dwellings Above the Ground Floor</u> : 60'	60' <u>MF &amp; Mixed-Use with Dwellings Above the Ground Floor</u> allowed 100' by conditional use by ordinance	60' <u>MF &amp; Mixed-Use with Dwellings Above the Ground Floor</u> allowed 100' by conditional use by ordinance	60' None
<b>MINIMUM BUILDING HEIGHT</b>	20'		20'	20'	20'	None
<b>FLOOR AREA RATIO</b>		Floor Area Ratio (FAR) = 0.8				



TABLE 10-401: COMMERCIAL ZONING DISTRICTS - BULK AND YARD REGULATIONS

BULK & YARD REGULATIONS	C-1	C-1-VC <sup>1</sup>	C-1-E	C-2	C-3	C-4
-------------------------	-----	---------------------	-------	-----	-----	-----

BULK REGULATIONS

<b>FRONT YARD</b>	None required, but a 5' maximum	20'	None required, but a 5' maximum	None required, but a 10' maximum	None	None, but all outdoor storage areas & parking areas that abut the street must be set back 10'
<b>INTERIOR SIDE YARD</b>	None required, but if provided must be a minimum of 10'	None required, but if provided must be a minimum of 10'	None required, but if provided must be a minimum of 10'	None required, but if provided must be a minimum of 10'	None required, but if provided must be a minimum of 10'	None, unless abutting a residential district or OR District, then 10'
<b>CORNER SIDE YARD</b>	First 25' from front lot line: 0' build-to line After first 25': None required	First 25' from front lot line: 0' build-to line Minimum setback of 25'	First 25' from front lot line: 0' build-to line After first 25': None required	None	None	None, but all outdoor storage areas that abut the street must be set back 10'
<b>REAR YARD</b>	20', unless rear yard abuts an alley, then none required	30'	20', unless rear yard abuts an alley, then none required	20', unless rear yard abuts an alley, then none required	20'	20'



TABLE 10-2: COMMERCIAL DISTRICTS - BULK & YARD REGULATIONS

BULK & YARD REGULATIONS	C-5 SUB-DISTRICTS						
	C-5-DC	C-5-IH	C-5-DE	C-5-HT	C-5-TO	C-5-HS	C-5-G
<b>BULK REGULATION</b>							
<b>MINIMUM BUILDING HEIGHT</b>	36'		36'	36'	36'	36'	36'
<b>MAXIMUM BUILDING HEIGHT</b>	None <sup>1</sup>	100'	125'	80'	175' <sup>1</sup>	175' <sup>1</sup>	80'
<b>MINIMUM YARD REQUIREMENTS</b>							
<b>FRONT YARD</b>	0' build-to line A front yard may be approved by conditional use	None required, but all development subject to site plan review	0' build-to line A front yard may be approved by conditional use	0' build-to line A front yard may be approved by conditional use	0' build-to line A front yard may be approved by conditional use	0' build-to line A front yard may be approved by conditional use	0' build-to line A front yard may be approved by conditional use
<b>INTERIOR SIDE YARD</b>	None	None	None	None	None	None	None
<b>CORNER SIDE YARD</b>	0' build-to line A corner side yard may be approved through the conditional use process	None required, but all development subject to site plan review approval	0' build-to line A corner side yard may be approved through the conditional use process	0' build-to line A corner side yard may be approved through the conditional use process	0' build-to line A corner side yard may be approved through the conditional use process	0' build-to line A corner side yard may be approved through the conditional use process	0' build-to line A corner side yard may be approved through the conditional use process
<b>REAR YARD</b>	None	None	None	None	None	None	None

TABLE 10-401: FOOTNOTES

<sup>1</sup> Subject to §10-503(k) for special building height provisions

<sup>2</sup> Where Table 10-401 does not indicate a separate standard for age-restricted housing or licensed residential care facilities for the elderly, the multi-family standards apply.

<sup>3</sup> In the C-1VC zoning district any change to existing setbacks or yards must be approved as variances by the Baltimore City Board of Municipal and Zoning Appeals



TABLE 10-503 (K): C-5 DISTRICTS DESIGN CRITERIA

DESIGN CRITERIA	C-5-DC	C-5-IH	C-5-DE	C-5-HT	C-5-TO	C-5-HS	C-5-G
Building design should reflect a distinct base, middle and top design.				X	X	X	
Incorporate design proportions within buildings so that all components of a building appear part of a unified whole.	X	X	X	X	X	X	X
Building design and siting should promote a pedestrian-orientation and pedestrian circulation.	X	X	X	X	X	X	X
Open space design should promote visually pleasing, safe and active space which emphasizes view, pedestrian access and solar exposure.	X	X	X	X	X	X	X
Building location and design should emphasize sustainability through convenient transit access, designs to collect stormwater runoff, landscape and façade design to minimize energy use, and adherence to LEED design principles.	X	X	X	X	X	X	X
Encourage signs scaled to the building design, appropriate to the street environment and oriented to both pedestrians and vehicles on streets.	X		X	X	X	X	X
Minimize the number of curb cuts and locate such to reduce the adverse impact upon the safety and comfort of pedestrians.	X	X	X	X	X	X	
Visually integrate parking facilities with surrounding development and encourage the active use of ground floors of parking structures.	X	X	X	X	X	X	X
Locate or screen service areas for trash, loading docks and mechanical equipment away from the street and/or pedestrian view.	X	X	X	X	X	X	X
The "tops" of new high-rise buildings in excess of 175' are encouraged to incorporate unique and distinctive designs, which create a distinctive and interesting Baltimore skyline. Examples of this type of "top" design include tops which exhibit a taper, pinnacle, sculptural or vertically punctuated condition, as shown in Figure 10-5: Building "Tops."	X		X	X	X	X	
The siting and design of buildings and structures shall consider the impact upon the present extent of views of iconic areas and buildings from within and into the downtown that define the image of the downtown. These include: Basilica of the Assumption, Bromo-Seltzer Tower, City Hall, Inner Harbor, Shot Tower, War Memorial, Washington Monument	X	X	X	X	X	X	X
Adhere to the guidelines of the West Side Strategic Plan, Part 11: Urban Design Guidelines.						X	
Adhere to the guidelines of the Pratt Street Plan for all development on Pratt Street.	X	X					





**TABLE 11-301: INDUSTRIAL DISTRICTS - PERMITTED AND CONDITIONAL USES**

USES	DISTRICTS					USE STANDARDS
	OIC	BSC	I-MU	I-1	I-2	
<b>RESIDENTIAL USES</b>						
Dwelling, Above the Ground Floor						
Dwelling: Rowhouse		P	P			
Dwelling, Multi-Family		P	P			
Residential Care Facility		P	P			Subject to §14-333
Residential Care Facility, 17 or larger		CB	CB			
Live/Work Dwelling			P	CB		
<b>INSTITUTIONAL USES</b>						
Cultural Facility			CB			Subject to §14-308
Educational Facility, Post-Secondary	CB	CB	CB			
Educational Facility, Primary/Secondary		P	P			
Educational Facility, Commercial/Vocational	P	P	P	P	CB	CB
Government Facilities – Public Works	P	P	P	P	P	P
Homeless Shelter			CO			
Hospital		P	CO			
<b>OPEN SPACE &amp; AGRICULTURAL USES</b>						
Parks and Playgrounds	P	P	P			
Community-Managed Open-Space Farm	P	P	P			Subject to §14-307
Community-Managed Open-Space Garden	P	P	P			Subject to §14-307
Urban Agriculture	P	P	P	P		Subject to §14-338
<b>COMMERCIAL USES</b>						
Animal Clinic			P	P		Subject to §14-317
Art Gallery			P			
Arts Studio			P			
Arts Studio – Industrial	P		P	P		
Body Art Establishment			P			
Banquet Hall	CB					
Broadcasting Station (TV or Radio)	P		P	P		
Car Wash				P	P	
Carry Out		P	P	CB	CB	
Day Care Center, Adult or Child	P	P	P	P <sup>1</sup>	P <sup>1</sup>	Subject to §14-309
Drive-Through Facility	CB					Subject to §14-311
Entertainment: Indoor		P	P			Subject to §14-312
Entertainment: live (Standalone Establishment)			CB			Subject to §14-319
Entertainment: Live – Secondary to Restaurant, Tavern, Arts Studio or Art Gallery		CB	CB			Subject to §14-319
Financial Institution	P <sup>2</sup>	P	P			
Gas Station				CB	CB	Subject to §14-314
Greenhouse/Nursery		P	P	P		



TABLE 11-301: INDUSTRIAL DISTRICTS - PERMITTED AND CONDITIONAL USES

USES	DISTRICTS							USE STANDARDS
	OIC	BSC	I-MU	I-1	I-2	MI		
Heavy Retail, Rental and Service			CO	CB				
Hotel/Motel	P	P	CB					Subject to §14-317
Kennel			CB	P				
Medical/Dental Clinic	P	P	P					Subject to §14-326
Motor Vehicle Service and Repair, Major								Subject to §14-326
Motor Vehicle Service and Repair, Minor			CO	CO				
Office	P	P	P	CB <sup>2,3</sup>	CB <sup>2,3</sup>	CB <sup>2,3</sup>		
Outdoor Dining			P					Subject to §14-329
Recreation: Indoor			P					Subject to §14-312
Recreation: Outdoor			CB					Subject to §14-312
Personal Services Establishment	P <sup>2</sup>	P	P	CB				
Restaurant	P <sup>2,6</sup>	P <sup>6</sup>	P <sup>6</sup>	CB <sup>6</sup>	CB <sup>6</sup>			
Restaurant General	C <sup>6</sup>	C <sup>6</sup>	C <sup>6</sup>	C <sup>6</sup>	C <sup>6</sup>	C <sup>6</sup>		Subject to §14-3XX
Restaurant Limited	P <sup>6</sup>	P <sup>6</sup>	P <sup>6</sup>	P <sup>6</sup>	P <sup>6</sup>			Subject to §14-3XX
Retail Goods Establishment - No Alcoholic Beverages Sales	CB	P	P	CB				
Retail Goods Establishment - With Alcoholic Beverages Sales		P <sup>6</sup>	CO <sup>6</sup>	CB <sup>6</sup>				Subject to §14-336
Lodge or Social Club			P	CB	CB	CB		Subject to §14-320
Tavern		P <sup>6</sup>	CO <sup>6</sup>	CB <sup>6</sup>	CB <sup>6</sup>			14-337?
Truck Repair				P	P			
<b>INDUSTRIAL USES</b>								
Alternative Energy: Commercial	P	P	P	P	P			
Boat Manufacturing, Repair and Sales			CB	P	P	CB		Subject to §14-303
Compositing: Commercial				CB	P			
Contractor Storage Yard				P	P			Subject to §14-330
Food Processing, Light	P		P	P				
Freight Terminal				P	P	P		
Heliport				CB	CB			
Helistop		CB		CB	CB			
Industrial Boat Repair Facility						P		Subject to §14-323
Industrial, Light	P	P	P	P	P			
Industrial, General						P	CB	Subject to §14-315
Industrial, Maritime-Dependent						P	P	
Landfill, Industrial					CB			Subject to §14-318
Marina: Dry Storage			CB	P	P			Subject to §14-323
Marine Terminal					P		P	
Materials Recovery Facility					P			
Mini-Warehouse			P	P				Subject to §14-324
Motor Vehicle Operations Facility				P	P			
Movie Studio	P		P	P	P			



**TABLE 11-301: INDUSTRIAL DISTRICTS - PERMITTED AND CONDITIONAL USES**

USES	DISTRICTS						USE STANDARDS
	OIC	BSC	I-MU	I-1	I-2	MI	
Outdoor Storage Yard				P	P	P	Subject to §14-330
Passenger Terminal			P	P	P	P	
Recyclable Materials Recovery Facility				P	P	P	
Research and Development	P	P	P	P	P	P	
Resource Recovery Facility					CB		Subject to §14-335
Shipyards					P	P	
Recycling and Refuse Collection Facility				P	P		
Truck Stop				P	P		
Truck Terminal				P	P		
Warehouse	P		P	P	P	P	
Waterfreight Terminal					P	P	
Wholesale Goods Establishment	P		P	P	P		
<b>OTHER</b>							
Alternative Energy Systems: Community Based	P	P	P	P	P	P	Subject to §14-306
Electric Substation: Enclosed	CB	CB	CB	CB	CB	CB	Subject to §14-339
Electric Substation: Indoor	CB	CB	CB	CB	CB	CB	Subject to §14-339
Electric Substation: Outdoor	CB	CB	CB	CB	CB	CB	Subject to §14-339
Parking Lot (Principal Use)	P	P	CO	P	P	P	Subject to §14-331
Parking Structure (Principal Use)	P	P	CO	P	P	P	Subject to §14-331
Utilities	CB	CB	CB	CB	CB	CB	Subject to §14-339
Telecommunications Facility	CB, P4	CB, P4	CB, P4	CB, P4	CB, P4	CB, P4	Subject to §14-340
Wireless Communication Service	CB, P5	CB, P5	CB, P5	CB, P5	CB, P5	CB, P5	

**TABLE 11-301: FOOTNOTES**

- <sup>1</sup> Allowed only when secondary to developments of large office structures, research and development facilities, and/or manufacturing uses, and integrated into the larger development to serve the employees.
- <sup>2</sup> Allowed only when secondary to principal industrial uses.
- <sup>3</sup> All legally established office uses as of the date of adoption of this Code are deemed conforming and are not required to be secondary to principal industrial use.
- <sup>4</sup> Only telecommunications antennas that comply with the stealth design standards of §14-338 (Wireless Telecommunications Antenna, Facility and Tower) are considered permitted uses.
- <sup>5</sup> Only Wireless Communication Services that are modifications to – and do not substantially change the physical dimension of – an existing telecommunication facility, are considered permitted.
- <sup>6</sup> All uses that do not engage in alcoholic Beverage sales can continue to operate in the manner listed in the tables. Any use that does not engage in alcoholic beverage sales must obtain a conditional use unless that type of use is not allowed in that particular district.



**TABLE 11-401: INDUSTRIAL DISTRICTS - BULK AND YARD REGULATIONS**

BULK REGULATION		OIC	BSC	I-MU	I-1	I-2	MI
<b>MINIMUM LOT AREA</b>		Minimum District Size: 1 acre Minimum Lot Area: None	Minimum District Size: 1 acre Minimum Lot Area: Residential Uses: 300sf/du All Other Uses: None	5,000sf Residential Uses: 300sf/du	10,000sf	20,000sf	20,000sf
<b>MAXIMUM BUILDING HEIGHT</b>		60'	150'; residential uses are allowed additional height above 150' (no limit) by conditional use	60'	60'	None, unless adjacent to a residential district or the OR, B-1, B-2 & B-3 Districts, then a 60' limitation for the first 50' adjacent to that district	None, unless adjacent to a residential district or the OR, B-1, B-2 & B-3 Districts, then a 60' limitation for the first 50' adjacent to that district
<b>MINIMUM YARD REQUIREMENTS</b>							
<b>FRONT YARD</b>		None	None	None, but all outdoor storage areas that abut the street must be set back 10'	10'	10'	10'
<b>FRONT PERIMETER YARD</b>		10'	10'				





TABLE 11-401: INDUSTRIAL DISTRICTS BULK AND YARD REGULATIONS

	OIC	BSC	I-MU	I-1	I-2	MI
<b>INTERIOR SIDE YARD</b>	None, unless abutting residential district, then 10'	None, unless abutting residential district, then 10'	None required, but a minimum of 10' if provided	None, unless abutting a Residential District or OR District, then 10'	None, unless abutting a Residential District or OR, B-1, B-2 or B-3 District, then 20'	None, unless abutting a Residential District or OR, B-1, B-2 or B-3 District, then 20'
<b>CORNER SIDE YARD</b>	None	None	None, but all outdoor storage areas that abut the street must be set back 10'	10'	10'	10'
<b>CORNER SIDE PERIMETER YARD</b>	10'	10'				
<b>REAR YARD</b>	None, unless abutting residential district, then 15'	None, unless abutting residential district, then 15'	None, unless abutting residential district, then 15'	None, unless adjacent to a residential district or the OR, B-1, B-2 & B-3 Districts, then 30'	None, unless adjacent to a residential district or the OR, B-1, B-2 & B-3 Districts, then 30'	None, unless adjacent to a residential district or the OR, B-1, B-2 & B-3 Districts, then 30'
<b>BUFFER YARD REQUIREMENT</b>			Where a landscaped buffer yard is required by the Landscape Manual between an industrial use & a non-industrial use, the more recent use must provide the buffer yard <sup>1</sup>	Where a landscaped buffer yard is required by the Landscape Manual between an industrial use & a non-industrial use, the more recent use must provide the buffer yard <sup>1</sup>	Where a landscaped buffer yard is required by the Landscape Manual between an industrial use & a non-industrial use, the more recent use must provide the buffer yard <sup>1</sup>	Where a landscaped buffer yard is required by the Landscape Manual between an industrial use & a non-industrial use, the more recent use must provide the buffer yard <sup>1</sup>

TABLE 11-401: FOOTNOTES

<sup>1</sup> For example, when a new commercial or residential development locates next to an existing industrial use, the new commercial use must provide the buffer yard. The existing industrial use is not considered nonconforming.



**TABLE 12-301: OFFICE-RESIDENTIAL DISTRICTS - PERMITTED AND CONDITIONAL**

USES	OR	USE STANDARDS
<b>RESIDENTIAL USES</b>		
Day Care Home, Child or Adult	P	Subject to §14-310
Dwelling, Detached	P	
Dwelling, Semi-Detached	P	
Rowhouse	P	
Dwelling, Multi-Family	P	Subject to §14-327
Fraternity/Sorority House	CO	Subject to §14-313
Residential Care Facility	P	Subject to §14-334
Licensed Residential Care Facility, 17 or larger	CO	
Rooming House, Small: 10 or Less Units	CO	
Rooming House, Large: 10 or More Units	CO	
<b>INSTITUTIONAL USES</b>		
Cultural Facility	P	Subject to §14-308
Educational Facility, Primary and Secondary	P	
Government Facilities - Public Works <sup>4</sup>	CB	
Place of Worship	P	Subject to §14-332
<b>COMMERCIAL USES</b>		
Bed and Breakfast	CB	Subject to §14-302
Broadcasting Station (TV or Radio)	CB	
Medical/Dental Clinic	P	
Neighborhood Commercial Establishment <sup>1</sup>	CB, P <sup>1</sup>	Subject to §14-328
Office	P	
Social Club or Lodge	CB	Subject to §14-320
<b>OPEN SPACE USES</b>		
Community-Managed Open-Space Farm	CB	Subject to §14-307
Community-Managed Open-Space Garden	P	Subject to §14-307
Parks and Playgrounds	P	
Urban Agriculture	CB	Subject to §14-339
<b>OTHER</b>		
Electric Substation: Enclosed	CB	Subject to §14-339
Electric Substation: Indoor	CB	Subject to §14-339
Electric Substation: Outdoor	CB	Subject to §14-339
Parking Lot (Principal Use)	CB	Subject to §14-331
Parking Structure (Principal Use)	CB	Subject to §14-331
Telecommunications Facility	CB, P <sup>2</sup>	Subject to §14-340
Utilities	CB	Subject to §14-339
Wireless Communications Service	CB, P <sup>3</sup>	

**TABLE 12-301 FOOTNOTES:**

<sup>1</sup> These uses are permitted for buildings with 50 residential units or more and they are limited to 10% gross floor area of building.

<sup>2</sup>Only telecommunications antennas that comply with the stealth design standards of §14-339 (Wireless Telecommunications Antenna, Facility and Tower) are considered permitted uses.

<sup>3</sup>Only Wireless Communication Services that are modifications to – and do not substantially change the physical dimension of – an existing telecommunication facility, are considered permitted.

<sup>4</sup> In these zoning districts, Government Facilities - Public Works' only pertain to water, wastewater, and stormwater systems



<b>TABLE 12-302: OFFICE-RESIDENTIAL DISTRICTS - BULK AND YARD REGULATIONS</b>		
<b>OR SUBDISTRICTS</b>		
	<b>OR-1</b>	<b>OR-2</b>
<b>BULK REGULATIONS</b>		
<b>MINIMUM LOT AREA</b>	550sf/du	200sf/du
<b>MAXIMUM BUILDING HEIGHT</b>	40'; however 60' may be allowed by conditional use permit	100'
<b>MINIMUM YARD REGULATIONS</b>		
<b>FRONT YARD</b>	None	None
<b>INTERIOR SIDE YARD</b>	None required, but a minimum of 10' if provided	None required, but a minimum of 10' if provided
<b>CORNER SIDE YARD</b>	10'	None
<b>REAR YARD</b>	10'	10'



**TABLE 12-402: TOD DISTRICTS - PERMITTED AND CONDITIONAL USES**

USES	TOD-1	TOD-2	TOD-3	TOD-4	USE STANDARDS
<b>RESIDENTIAL USES</b>					
Dwelling, Above the Ground Floor	P	P	P	P	
Dwelling, Multi-Family	P	P	P	P	Subject to §14-327
Dwelling: Rowhouse	P	P	P	P	
Residential Care Facility	P	P	P	P	Subject to §14-334
Residential Care Facility, 17 or larger	CB	CB	CB	CB	
<b>INSTITUTIONAL USES</b>					
Community Center	P	P	P	P	
Cultural Facility	P	P	P	P	Subject to §14-308
Government Facilities - Public Works <sup>5</sup>	CB	CB	CB	CB	
Educational Facility, Primary/Secondary	P	P	P	P	
Educational Facility, Commercial/Vocational	P	P	P	P	
Educational Facility, Post-Secondary	P	P	P	P	
Homeless Shelter	P	CB	P	CB	
Place of Worship		P		P	Subject to §14-332
<b>OPEN SPACE AND AGRICULTURAL USES</b>					
Community-Managed Open-Space Farm	P	P	P	P	Subject to §14-307
Community-Managed Open-Space Garden	P	P	P	P	Subject to §14-307
Parks and Playgrounds – Passive Recreation Only <sup>1</sup>		P		P	
<b>COMMERCIAL USES</b>					
Animal Clinic	P		P	P	Subject to §14-317
Art Gallery	P	P	P	P	
Arts Studio		P		P	
Banquet Hall		CO		CO	
Day Care Center, Child or Adult	P	P	P	P	Subject to §14-309
Entertainment: Indoor		P		P	Subject to §14-311
Entertainment: Live		CB		CB	Subject to §14-320
Financial Institution		P		P	
Health Center	P	P	P	P	
Hotel/Motel		P		P	
Kennel				C	Subject to §14-317
Lodge or Social Club		CO		CO	Subject to §14-320
Medical/Dental Clinic	P	P	P	P	
Office	P	P	P	P	
Outdoor Dining	P	P	P	P	Subject to §14-329
Personal Services Establishment	P	P	P	P	
Recreation: Indoor		P		P	Subject to §14-312
Restaurant	P <sup>2,6</sup>	P <sup>6</sup>	P <sup>2,6</sup>	P <sup>6</sup>	
Restaurant General	C <sup>6</sup>	C <sup>6</sup>	C <sup>6</sup>	C <sup>6</sup>	Subject to §14-3XX
Restaurant Limited	P <sup>6</sup>	P <sup>6</sup>	P <sup>6</sup>	P <sup>6</sup>	Subject to §14-3XX
Retail Goods Establishment – No Alcoholic Beverages Sales	P <sup>2</sup>	P	P <sup>2</sup>	P	
Retail Goods Establishment – With Alcoholic Beverages Sales		P <sup>6</sup>		P <sup>6</sup>	Subject to §14-336





**TABLE 12-402: TOD DISTRICTS - PERMITTED AND CONDITIONAL USES**

USES	TOD-1	TOD-2	TOD-3	TOD-4	USE STANDARDS
Tavern	CB <sup>6</sup>	P <sup>6</sup>	CB <sup>6</sup>	P <sup>6</sup>	
<b>OTHER</b>					
Electric Substation: Enclosed	CB	CB	CB	CB	Subject to §14-339
Electric Substation: Indoor	CB	CB	CB	CB	Subject to §14-339
Electric Substation: Outdoor	CB	CB	CB	CB	Subject to §14-339
Parking Lot (Principal Use)	CB	CB	CB	CB	Subject to §14-331
Parking Structure (Principal Use)	CB	CB	CB	CB	Subject to §14-331
Telecommunications Facility	CB, P <sup>3</sup>	CB, P <sup>3</sup>	CB, P <sup>3</sup>	CB, P <sup>3</sup>	Subject to §14-340
Utilities	CB	CB	CB	CB	Subject to §14-339
Wireless Communications Services	CB, P <sup>4</sup>	CB, P <sup>4</sup>	CB, P <sup>4</sup>	CB, P <sup>4</sup>	

**TABLE 12-402 FOOTNOTES:**

<sup>1</sup> No recreation facilities are allowed within parks and playgrounds, with the exception of standard playground equipment and outdoor furniture.

<sup>2</sup> Limited to 5,000sf in gross floor area.

<sup>3</sup> Only telecommunications antennas that comply with the stealth design standards of §14-339 (Wireless Telecommunications Antenna, Facility and Tower) are considered permitted uses.

<sup>4</sup> Only Wireless Communication Services that are modifications to – and do not substantially change the physical dimension of – an existing telecommunication facility, are considered permitted.

<sup>5</sup> In these zoning districts, 'Government Facilities: Public Works' only pertain to water, wastewater, and stormwater systems

<sup>6</sup> All uses that do not engage in alcoholic Beverage sales can continue to operate in the manner listed in the tables. Any use that does not engage in alcoholic beverage sales must obtain a conditional use unless that type of use is not allowed in that particular district.



**TABLE 12-403: TOD DISTRICTS - BULK AND YARD STANDARDS**

<b>BULK AND YARD REQUIREMENTS</b>	<b>TOD-1</b>	<b>TOD-2</b>	<b>TOD-3</b>	<b>TOD-4</b>
<b>BULK REGULATIONS</b>				
<b>MINIMUM LOT AREA</b>	Residential: 300 sf/du Other Uses: None	None	Residential: 300 sf/du Other Uses: None	None
<b>MINIMUM LOT WIDTH</b>	None	None	None	None
<b>MINIMUM BUILDING HEIGHT</b>	24' or 2 stories	24' or 2 stories	24' or 2 stories	24' or 2 stories
<b>MAXIMUM BUILDING HEIGHT</b>	60' or 5 stories	60' or 5 stories ; up to 100' is permitted by conditional use	100'; additional height above 100' (no limit) is permitted by conditional use	100'; additional height above 100' (no limit) is permitted by conditional use
<b>YARD REQUIREMENTS</b>				
<b>FRONT YARD<sup>1</sup></b>	None required, but if provided a maximum of 5'	None required, but if provided a maximum of 5'	None required, but if provided a maximum of 5'	None required, but if provided a maximum of 5'
<b>INTERIOR SIDE YARD</b>	None	None	None	None
<b>CORNER SIDE YARD</b>	None	None	None	None
<b>REAR YARD</b>	15'	15'	None	None

**TABLE 12-403 FOOTNOTES:**

<sup>1</sup> The front yard may be increased if a courtyard, plaza or seating area is incorporated into the development adjacent to the public street.



**TABLE 12-502: EDUCATIONAL CAMPUS DISTRICTS - BULK AND YARD REGULATIONS**

	EC-1 DISTRICT	EC-2 District
<b>BULK REGULATIONS</b>		
<b>MINIMUM LOT AREA</b>	2 acres or 1 City block	2 acres or 1 City block
<b>MAXIMUM BUILDING HEIGHT</b>	35'	65'
<b>FLOOR AREA RATIO</b>	In addition to overall height limit of 35' there is a Floor Area Ratio (FAR) = .8	
<b>MINIMUM YARD REGULATIONS</b>		
<b>FRONT YARD</b>	None	None
<b>FRONT PERIMETER YARD</b>	20'	10'
<b>INTERIOR SIDE YARD</b>	None, unless abutting residential district, then 20'	None, unless abutting residential district, then 10'
<b>CORNER SIDE YARD</b>	None	None
<b>CORNER SIDE PERIMETER YARD</b>	20'	10'
<b>REAR YARD</b>	None, unless abutting residential district, then 40'	None, unless abutting residential district, then 15'



**TABLE 12-602: HOSPITAL CAMPUS DISTRICT - BULK AND YARD REGULATIONS**

HC DISTRICT	
<b>BULK REGULATIONS</b>	
<b>MINIMUM LOT AREA</b>	2 acres or 1 City block
<b>MAXIMUM BUILDING HEIGHT</b>	<p>When adjacent to R-1 to R-8 Districts: 40' at district boundaries and then may rise at a 45° angle to a maximum height of 150'</p> <p>When adjacent to C-1 to C-4 Districts and R-9 and R-10 Districts: 65' at district boundaries and then may rise at a 45° angle to a maximum height of 150'</p> <p>When adjacent to all other districts: 150' or the highest existing building on the campus on the effective date of this code</p>
<b>MINIMUM YARD REGULATIONS</b>	
<b>FRONT YARD</b>	None
<b>FRONT PERIMETER YARD</b>	10'
<b>INTERIOR SIDE YARD</b>	None, unless abutting residential district, then 10'
<b>CORNER SIDE YARD</b>	None
<b>CORNER SIDE PERIMETER YARD</b>	10'
<b>REAR YARD</b>	None, unless abutting residential district, then 15'





Table 12-903(1): Canton Waterfront Area - Page 1 of 3

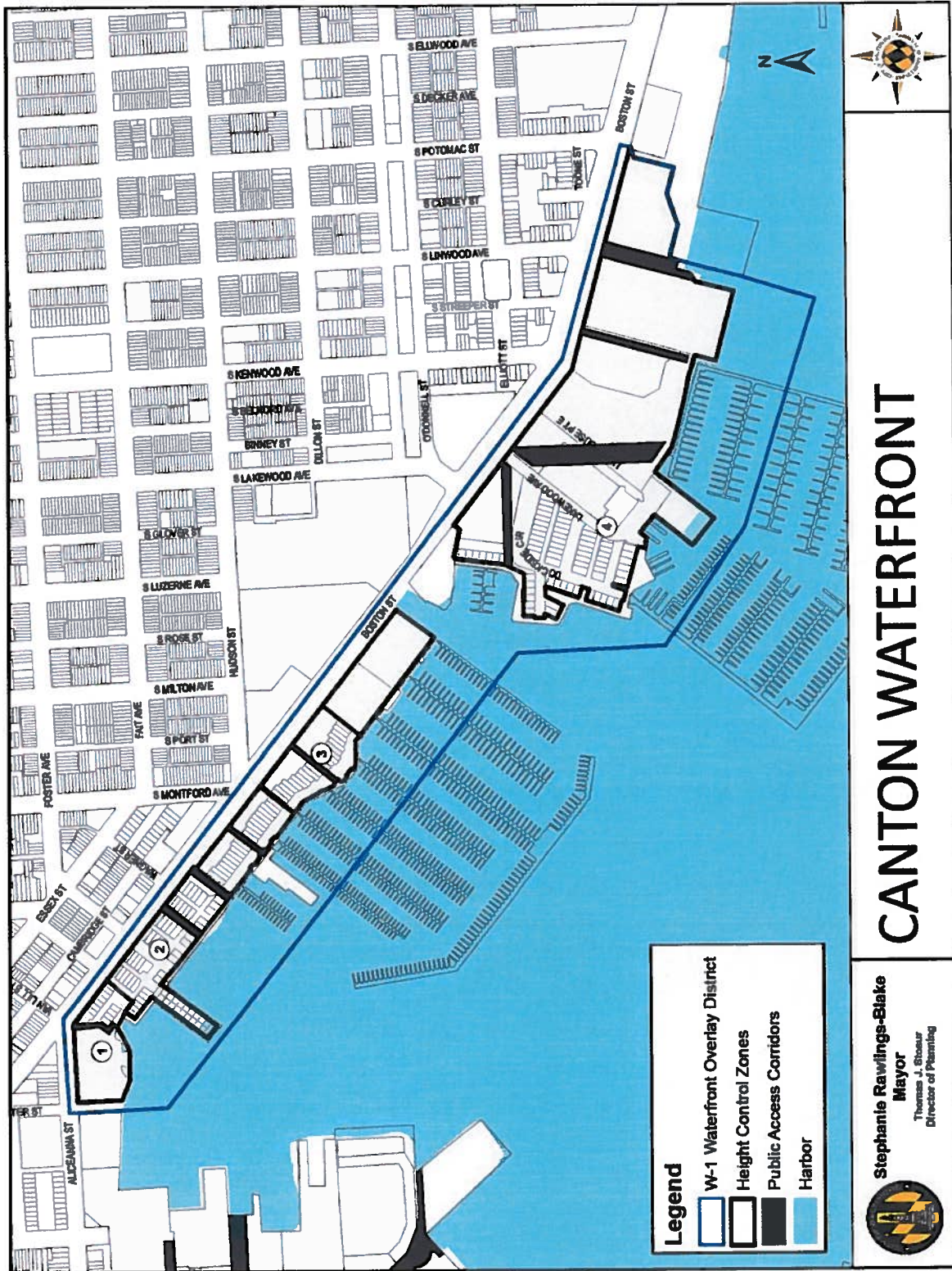



**Table 12-903(1): Canton Waterfont Area - Page 2 of 3**

**Height Limitations** - The height of structures along the waterfront shall not exceed 35 feet, except in Areas 1 through 4. Height controls are provided in Areas 1 through 4 to minimize the impact of building heights on adjacent neighborhoods. Specific locations for higher buildings are provided, as well as guidelines for building setbacks and setbacks. The maximum building height shall be defined as the vertical distance measured, in the case of flat roofs, from the mean curb level of the highest point of the roof adjacent to the street wall, and in the case of pitched roofs, from the mean curb level to the mean height level of the roof. Where the walls of a building are not adjacent to a street curb, the height of a building shall be measured from the average elevation of the ground adjoining the walls.

Canton Waterfont Area Height Limitations	
Area	Height Limitations
<b>1</b>	<p>Average height of the built area may not exceed 45 feet Maximum building height may be 50 feet</p> <p>Maximum building height along Aliceanna Street, Chester Street and the water's edge may be 40 feet. Additional height above 40 feet up to the maximum of 50 feet may be constructed so that it is not visible from that portion of the promenade adjacent to the area or may step up at an angle of no more than 45 degrees. The building may be setback a minimum of 20 feet from the Chester Street right-of-way.</p>
<b>2</b>	<p>Average height of the built area may not exceed 65 feet;</p> <p>Maximum height, excluding HVAC or other mechanical systems, is 75 feet.</p> <p>Maximum height for the HVAC and other mechanical systems may not exceed 90 feet.</p> <p>The maximum building height on Boston Street, the northwest and the water's edge may be 60 feet. Additional height above 60 feet up to the maximum of 75 feet may be constructed so it is not visible from that portion of the promenade adjacent to the area and from the sidewalk on the north side of Boston Street adjacent to the area or may step up at an angle of no more than 45 degrees.</p>
<b>3</b>	<p>The water's edge may have a maximum height of 40 feet.</p> <p>Additional height above 40 feet up to a maximum height no higher than the existing properties at 2351- 2439 Boston Street may be constructed so that it is not visible from that portion of the promenade adjacent to the area or may step up at an angle of no more than 45 degrees.</p>
<b>4</b>	<p>Average height of the built area may not exceed 50 feet Maximum height is 79 feet.</p> <p>The water's edge may have a maximum height of 40 feet. Additional height above 40 feet may be setback at an angle of no more than 45 degrees up to 79 feet.</p>



**Table 12-903(1): Canton Waterfront Area - Page 3 of 3**

**Public Access Corridors** - Minimum width of the corridors may be 50 feet, unless otherwise noted below. Landscaping, trees, lights, benches, tables, and other public amenities that will enhance, not impede, public view of the water may be permitted. All access corridors should connect sidewalk and promenade and be physically and visually uninterrupted. In cases where a public access corridor is to be located between 2 properties, the center of the corridor may be on the property line and the width of the corridor may be evenly divided between the 2 properties.

Canton Waterfront Public Access Corridors	
Corridor	Location
1	From a point at the approximate intersection of Boston and Aliceanna Streets south to the water between 2201 and 2121 Boston Street.
2	A 30 foot wide public access corridor may be designated between 2301 Boston Street (Northshore) and 2351 Boston Street (Anchorage Townhomes), consisting of a 15 foot wide public access corridor each on 2301 Boston Street and 2351 Boston Street.
3	A 15-foot wide public access corridor may be designated between 2369 and 2371, between 2389 and 2401, and between 2419 and 2421 Boston Street.
4	A 30-foot wide public access corridor may be designated between 2439 and 2449 Boston Street.
5	From a point at the approximate intersection of Luzerne Avenue and Hudson Street due south along the axis of Luzerne Avenue to the waterfront park. In the Luzerne Avenue corridor, if financially necessary and subject to the review and approval of the Commissioner of Housing and Community Development, a second level pedestrian bridge may be allowed.
6	From a point at the approximate intersection of Lakewood Avenue and Boston Street due south along the axis of Lakewood Avenue through to the water.
7	From a point at the approximate intersection of Kenwood Avenue and Boston Street along the axis of the existing 2809 Boston Street approximately southwest to the water.
8	From a point at the approximate intersection of Linwood Avenue and Boston Street along the axis of the existing 2809 Boston Street approximately southwest to the water.
9	This public access corridor may be described by a set of parallel lines. The northern line may extend west from the intersection of Elliott Street and Kenwood Avenue along the north axis of Elliott Street to the water; the southern will be parallel and 50 feet south of the above line.



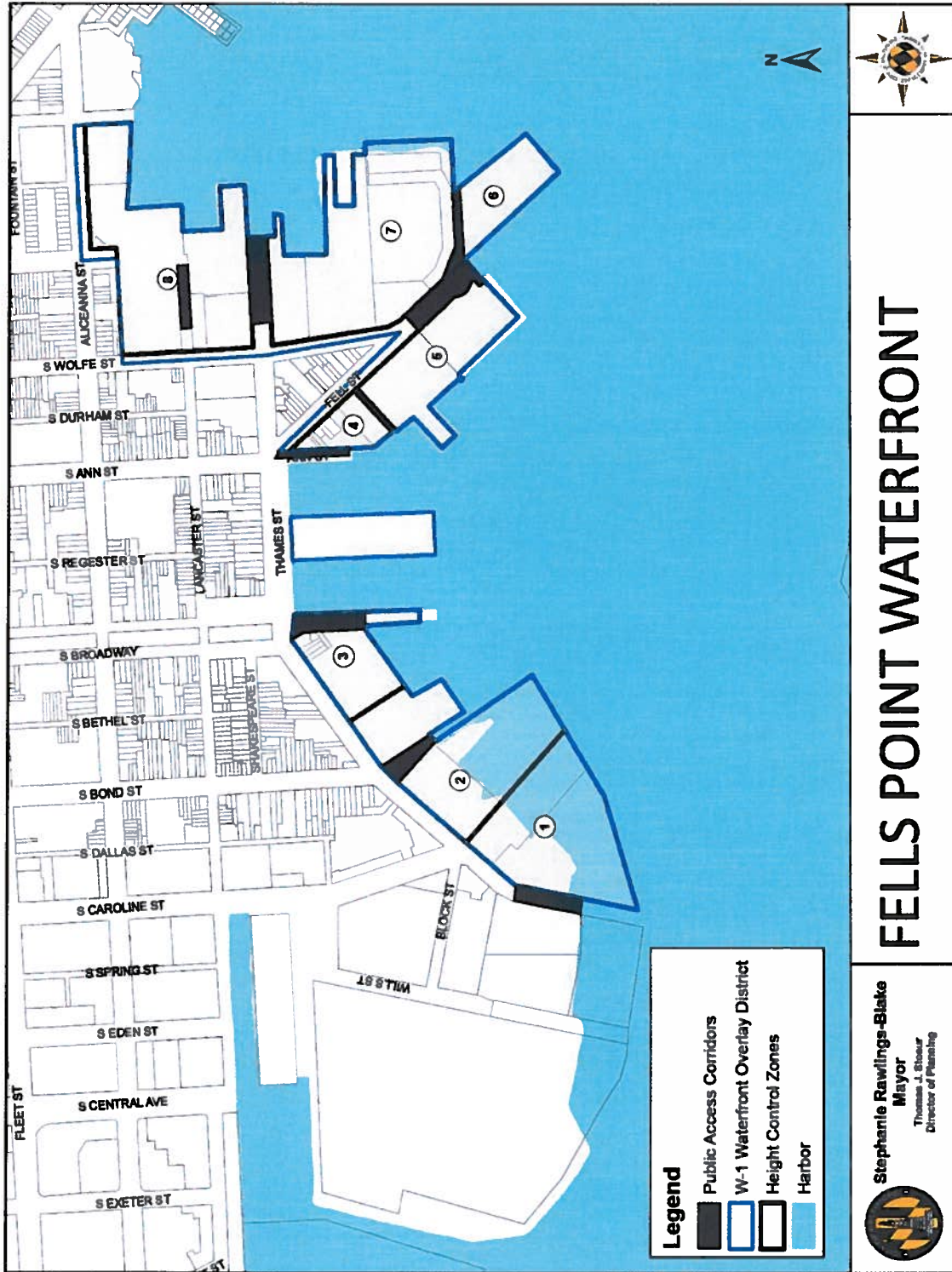





Table 12-903(2): Fells Point Waterfront Area – Page 2 of 3

**Height Limitations** - The maximum building height may be defined as the vertical distance measured, in the case of flat roofs, from the mean curb level of the highest point of the roof adjacent to the street wall, and in the case of pitched roofs, from the mean curb level to the mean height level of the roof. Where the walls of a building are not adjacent to a street curb, the height of a building may be measured from the average elevation of the ground adjoining the walls.

Fells Point Waterfront Area Height Limitations	
Area	Height Limitations
1	The maximum building heights may be as set forth in the Constellation PUD.
2	The maximum building heights may be as set forth in the Constellation PUD.
3	Thames Street elevations may be no higher than 40 feet. A building addition up to a maximum of 53 feet will be permitted if it is set back and designed so that it is not visible from the street frontage opposite this area.
4	Maximum building height may not exceed 40 feet.
5	Maximum building height may not exceed 60 feet, except on the property known as 1000 Fell Street where rehabilitation of the roof structure to accommodate a seventh story is permitted, provided that this seventh story is recessed so as not to be Subject ton from the street frontage of the subject property, and a further exception is provided for the property known as 932-944 Fell Street (Belt's Wharf Condominium Property) for a building addition up to a maximum of 74 feet if recessed 40 feet from the street frontage of the property.
6	The average height of built area may be no more than 50 feet, with a maximum height of 60 feet. The maximum height along the water's edge is 40 feet. Additional height over 40 feet up to the maximum of 60 feet may be constructed so that it is not visible from that portion of the promenade adjacent to the area or may step up at an angle of no more than 45 degrees.
7	The average height of built area may be no more than 75 feet, with a maximum height of 90 feet. The maximum height along Wolfe Street and the water's edge is 40 feet. The maximum height along Thames Street is 60 feet. Additional height over the 40 feet and 60 feet up to the maximum of 90 feet may be constructed so that it is not visible from that portion of the promenade adjacent to the area, Wolfe Street or Thames Street or may step up at an angle of no more than 45 degrees.
8	The average height of built area may be 45 feet, with a maximum height of 65 feet. The maximum height on Aliceanna Street, Chester Street and the water side may be 40 feet for a minimum of 40 feet depth. The building may be set back a minimum of 20 feet from the Chester Street right-of-way. Additions to the existing building at 705 S. Wolfe Street are permitted up to 65 feet. These additions may be set back so as not to be Subject ton from Wolfe Street, Aliceanna Street and the promenade adjacent to the area.



**Table 12-903(2): Fells Point Waterfront Area – Page 3 of 3**

**Public Access Corridors** - In order to assure public access to the Pedestrian Promenade and to preserve and enhance views of the water, the following public access corridors may be designated. The minimum width of the corridors may be 50 feet. Landscaping, trees, lights, benches, tables, and other public amenities that will enhance, not impede, public view of the water may be permitted. Off-street parking is not permitted within these corridors, except following review and approval of the Commissioner of the Department of Housing and Community Development. All access corridors should connect sidewalk and promenade and be physically and visually uninterrupted, and they must be accessible 24 hours daily. The general location of the following public access corridors are shown on the accompanying exhibit.

Fells Point Waterfront Public Access Corridors	
Corridor	Location
1	From a point at the approximated intersection of Thames, Philpot and Caroline Streets extended south to the water.
2	From a point at the approximate intersection of Thames and existing Caroline Street southeast to the water.
3	From the eastern right-of-way of Bond and Thames Streets, 50 feet west to a point, southeast to the water's edge to a point, 100 feet east on the water's edge to the point of the existing right-of-way of Bond Street north to the intersection of Bond and Thames Streets
4	From the end of Broadway south to the water.
5	From the end of Ann Street south to the water.
6	From a point approximately in front of 929 Fell Street southwest to the water.
7	From a point at the end of Fell Street east to the water along the property line between 1001 Fell Street and 935 S. Wolfe Street. The corridor may extend 25 feet on either side of the property line.
8	From a point at the intersection of Washington Street extended and Thames Street south to the water.
9	From point at the approximate intersection of Fell and Wolfe Streets southeast to the water.
10	From the end of Thames Street east to the water.
11	From the end of Lancaster Street east to the water.
12	From a point at the approximate intersection Aliceanna and Chester Streets south to the water
13	The following public streets – Broadway, Ann and Chester Streets – may be designated as long view corridors. New obstructions, such as balconies, bridges or structures may be permitted only with prior approval of the Commissioner of the Department of Housing and Community Development
14	From a point at the approximate intersection of the realigned Wills Street ad Philpot Street south to the water



Table 12-903(3): Key Highway Waterfront Area - Page 1 of 3

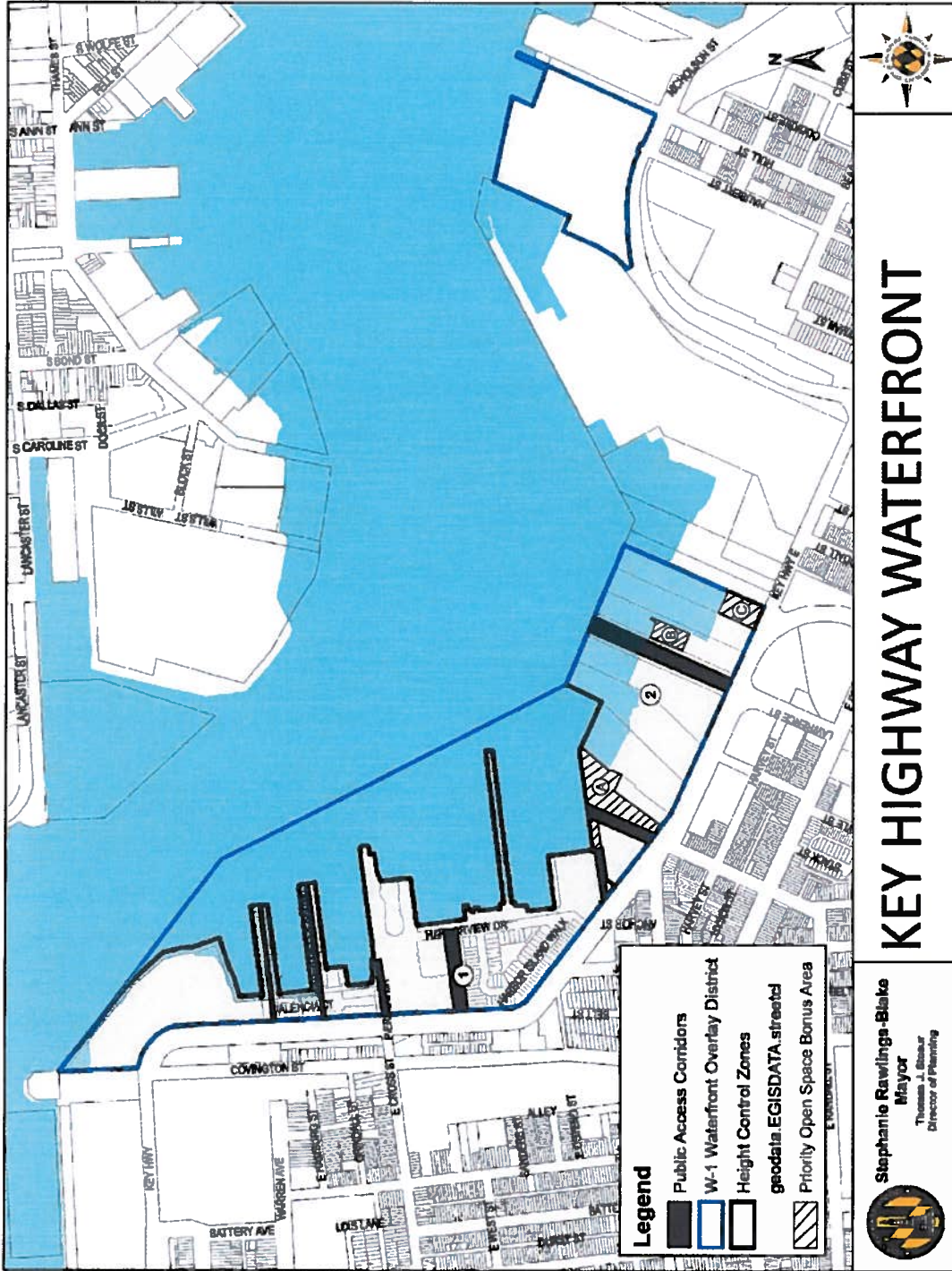



**Table 12-903(3): Key Highway Waterfront Area - Page 2 of 3**

Key Highway Height Controls	
Area	Height Limitations
<b>1</b>	<p>Building height may not exceed 290 feet above Mean Low Tide. Building coverage in this area may not exceed the following percentages of the existing aggregate of those areas:</p> <ul style="list-style-type: none"> <li>a) Grade to El. 58 feet: 65%</li> <li>b) El. 58 feet to El. 150 feet: 30%</li> <li>c) El. 150 feet to El. 390 feet: 16%</li> </ul> <p>Maximum height of El. 58 feet in the area north of the eastward extension of Grindall Street and Key Highway.</p> <p>No structure located between El. 150 feet and El. 390 feet shall exceed 14,000 square feet in area nor be located less than 100 feet from any structure located between El. 150 feet and El. 390 feet.</p> <p>Rooftop mechanical equipment may exceed such a maximum permitted elevations, as approved by DHCD.</p>
<b>2</b>	<p>Minimum Building Height along Key Highway – 35 feet                      Maximum Base Building Height – 60 feet                      15 foot setback for building above 40 feet along Key Highway                      All new buildings shall be setback a minimum of 18' from the existing curb line of Key Highway.</p> <p>Towers (building above 60 feet base building height) subject to the following:                      Maximum Floor-plates above 60 feet – 11,000 Gross Square Feet (GSF)                      Spaced no less than 100 feet from another tower                      Maximum Total Building Height – 140 feet.</p> <p>Priority Open Space Bonus: additional height and density above 140 feet may be earned for the development of priority open space in Areas A, B, and C as labeled on the Table 12-903(3) Key Highway Waterfront Area, at a rate of 10 GSF building/ 1.0 GSF of priority open space provided. Only bonus density may be used above 140 feet. Maximum building height with bonuses shall not exceed 290 feet. Priority Open Space created to calculate bonus density may not exceed 37,500 total square feet in Area A and may not exceed 28,000 total square feet in Areas B and C combined. Priority open space does not include the required Promenade and is to be built and maintained by the landowner for credit. Open spaces shall be established by public easements granted to the City.</p>





View Corridors/Public Access:

Key Highway Public Access/View Corridors	
Area	Public Access / View Corridors
1	Public Access Corridors must be provided from Key Highway to the water's edge from the five locations shown and connect the public sidewalk along Key Highway to the Public Promenade.
2	Public Access Corridors must be a minimum of 20 feet in width of permanently constructed hardscape within a Public View Corridor. The associated View Corridor must be a minimum of 60 feet wide that connects the public sidewalk along Key Highway to the Public Promenade.



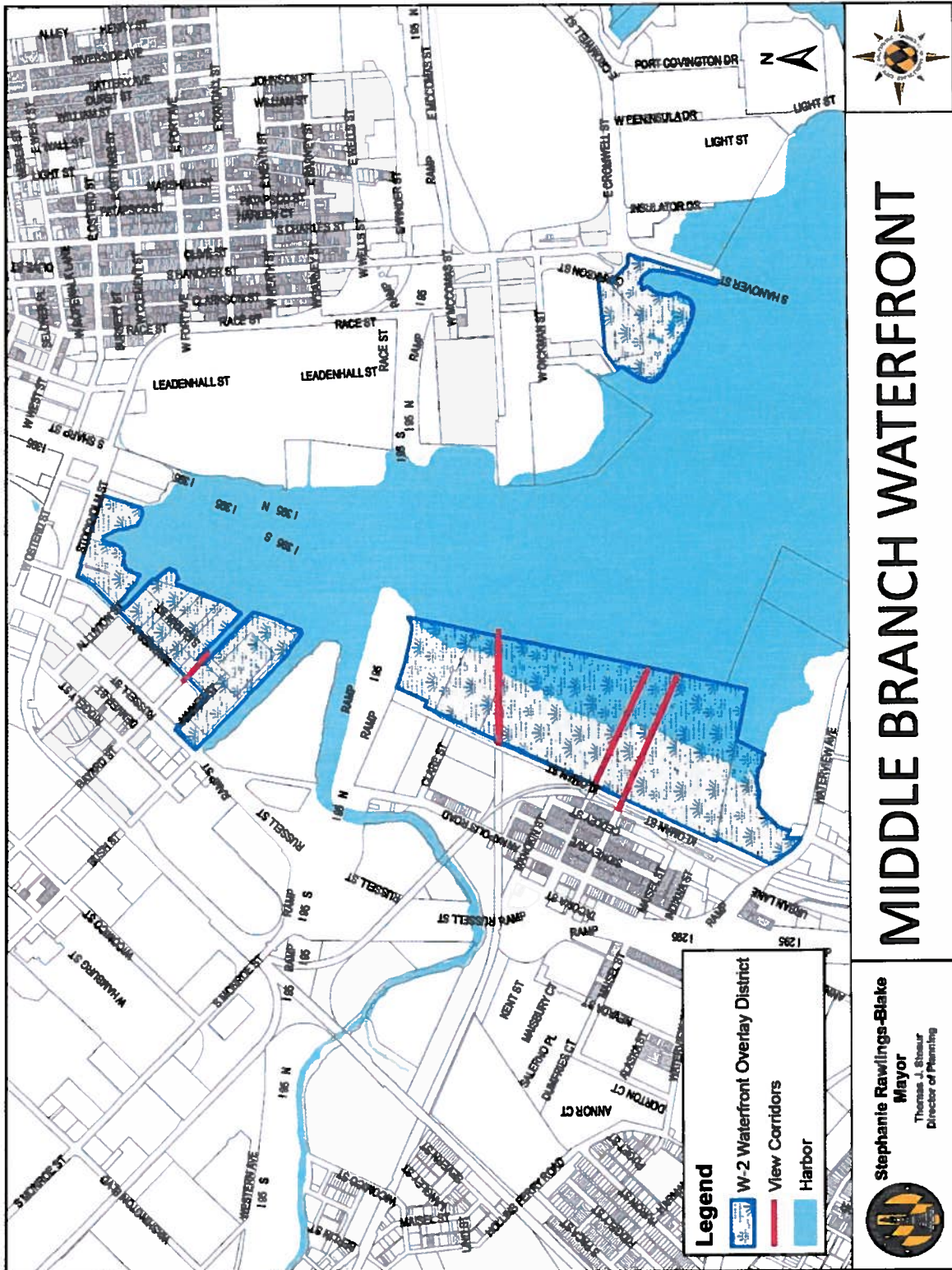



**TABLE 12-1302 PORT COVINGTON DISTRICT - PERMITTED AND CONDITIONAL USES**

USE					USE STANDARDS
	PC-1	PC-2	PC-3	PC-4	
<b>RESIDENTIAL USE</b>					
Dwelling Multi-Family	P	P	P		Subject to §14-327
Dwelling: Above The Ground Floor	P	P	P		
Dwelling: Rowhouse			P		
Day Care Home: Adult or Child	P	P	P		Subject to §14-310
Fraternity and Sorority House		P	P		
Live-Work Dwelling	P	P	P		
Residential Care Facility	P	P	P		Subject to §14-333
Residential Care Facility, 17 or larger	P	CB	P		
<b>INSTITUTIONAL USE</b>					
Community Center	P	P	P	P <sup>1</sup>	
Cultural Facility	P	P	P	P <sup>1</sup>	Subject to §14-308
Educational Facility: Commercial/Vocational		P	P	P <sup>1</sup>	
Educational Facility: Primary and Secondary		P	P	P <sup>1</sup>	
Educational Facility: Post-Secondary		P	P	P <sup>1</sup>	
Government Facilities - Public Works	P	P	P	P	
Homeless Shelter		CB	CB		
Hospital		P	P		
Place of Worship	P	P	P		Subject to §14-332
<b>OPEN SPACE AND AGRICULTURAL USE</b>					
Community-Managed Open-Space Farm	P	P	P	P	Subject to §14-307
Community-Managed Open-Space Garden	P	P	P	P	Subject to §14-307
Fishing Pier	P	P	P	P	
Forest and Nature Preserve	P	P	P	P	
Horse Stable	P	P	P		
Marina: Recreational	p <sup>2</sup>	p <sup>2</sup>	p <sup>2</sup>	P <sup>1,2</sup>	Subject to §14-323



**TABLE 12-1302 PORT COVINGTON DISTRICT - PERMITTED AND CONDITIONAL USES**

USE					USE STANDARDS
	PC-1	PC-2	PC-3	PC-4	
Parks and Playgrounds	P	P	P	P	
Recreational Boat Launch	P	P	P	P	
Urban Agriculture	P	P	P	P	Subject to §14-339
Zoo	CB	CB	CB		
<b>COMMERCIAL USE</b>					
Amusement and Carnival Rides	P	P	P		
Animal Clinic		P	P		
Art Gallery	P	P	P	P <sup>1</sup>	
Arts Studio	P	P	P		
Arts Studio - Industrial	P	P	P		
Banquet Hall	P	P	P	P <sup>1</sup>	
Body Art Establishment	P	P	P	P <sup>1</sup>	
Broadcasting Station (TV or Radio)	P	P	P	P	
Car wash - fully enclosed structure		P	P	P <sup>1</sup>	Subject to §14-304
Car wash - outdoor		CB	C	P <sup>1</sup>	Subject to §14-304
Carry-Out	P	P	P	P <sup>1</sup>	
Check Cashing Establishment	CB	CB	CB	CB <sup>1</sup>	
Convention Center		P	P	P <sup>1</sup>	
Country Club		P	P	P <sup>1</sup>	
Day-Care Center: Adult or Child		P	P	P <sup>1</sup>	Subject to §14-309
Drive-thru facility	P	P	P		Subject to §14-311
Driving Range - Golf		P	P	P	
Entertainment: Indoor	P	P	P	P <sup>1</sup>	Subject to §14-312
Entertainment: Live - Secondary to Restaurant, Tavern , Art Studio or Art Gallery	P	P	P	P <sup>1</sup>	Subject to §14-319
Entertainment: Live (Stand Alone Establishment)	P	P	P	P <sup>1</sup>	Subject to §14-319
Fairground		P	P		





**TABLE 12-1302 PORT COVINGTON DISTRICT - PERMITTED AND CONDITIONAL USES**

USE					USE STANDARDS
	PC-1	PC-2	PC-3	PC-4	
Financial Institution	P	P	P	P <sup>1</sup>	
Food and Beverage Processing: Light	P	P	P	P	
Funeral Home	P	P	P	P	
Gas Station		P	P		Subject to §14-314
Greenhouse/Nursery	P	P	P	P <sup>1</sup>	
Health Center		P	P	P <sup>1</sup>	
Hotel/Motel	P	P	P	P	
Kennel		P	P		Subject to §14-317
Lodge or Social Club	P	P	P	P <sup>1</sup>	Subject to §14-320
Medical/Dental Clinic		P	P	P <sup>1</sup>	
Motor Vehicle Dealership - Fully Enclosed Structure		P	P		Subject to §14-325
Motor Vehicle Dealership - With Outdoor Display		P	P		Subject to §14-325
Motor Vehicle Rental Establishment - Fully Enclosed Structure		P	P	P <sup>1</sup>	Subject to §14-325
Motor Vehicle Rental Establishment - With Outdoor Display		P	P		Subject to §14-325
Motor Vehicle Service and Repair Minor - With Outdoor Storage of Vehicles		P	P		Subject to §14-326
Motor Vehicle Service and Repair, Major		P	P		Subject to §14-326
Motor Vehicle Service and Repair, Minor - Fully Enclosed Structure		P	P	P <sup>1</sup>	Subject to §14-326
Office	P	P	P	P	
Outdoor Dining	P	P	P	P <sup>1</sup>	Subject to §14-329
Pawn Shop		CB	CB		
Personal Services Establishment	P	P	P	P <sup>1</sup>	
Racetrack		P	P		
Recreation : Indoor	P	P	P	P	Subject to §14-312
Recreation: Outdoor	P	P	P	P	Subject to §14-312
Recreational Vehicle Dealership			P		
Restaurant	P <sup>6</sup>	P <sup>6</sup>	P <sup>6</sup>	P <sup>1,6</sup>	



**TABLE 12-1302 PORT COVINGTON DISTRICT - PERMITTED AND CONDITIONAL USES**

USE					USE STANDARDS
	PC-1	PC-2	PC-3	PC-4	
Retail Goods Establishment - No Alcohol Sales	P	P	P	P <sup>1</sup>	
Retail Goods Establishment - With Alcohol Sales	P <sup>6</sup>	P <sup>6</sup>	P <sup>6</sup>	P <sup>1,6</sup>	Subject to §14-335
Stadium		P	P	P	
Tavern	P <sup>6</sup>	P <sup>6</sup>	P <sup>6</sup>	P <sup>1,6</sup>	
Video Lottery Facility		P	P		
Water-Taxi Stop	P	P	P	P	
<b>INDUSTRIAL USE</b>					
Alternative Energy Systems: Commercial	P	P	P	P	
Boat Manufacturing and Repair and Sales	CB	P	P		Subject to §14-303
Composting - Commercial		CB	P		Subject to §14-305
Contractor Storage Yard		CB	P		Subject to §14-330
Freight Terminal		CB	P		
Heavy Sales, Rental or Service		CB	P		
Heliport	P	P	P	P	
Helistop	P	P	P	P	
Industrial Boat Repair Facility		P	P		
Industrial Maritime Dependent		P			
Industrial: General		P	P	P	Subject to §14-315
Industrial: Light		P	P	P	
Marina Dry Storage		P	P		Subject to §14-323
Marine Terminal		CB	CB		
Materials Recovery Facility		CB	P		Subject to §14-324
Mini-warehouse		P	P		
Motor Vehicle Operation Facility		P	P		
Movie Studio		P	P		
Outdoor Storage Yard		CB	P	P	Subject to §14-330



**TABLE 12-1302 PORT COVINGTON DISTRICT - PERMITTED AND CONDITIONAL USES**

USE					USE STANDARDS
	PC-1	PC-2	PC-3	PC-4	
Passenger Terminal	P	P	P		
Printing Establishment		P	P		
Recyclable Materials Recovery Facility		CB	P		
Research and Development	P	P	P	P	
Resource Recovery Facility		CB	CB		Subject to §14-335
Shipyards		P	P		
Truck Stop		CB	CB		
Truck Terminal		CB	CB		
Warehouse		P	P	P	
Waterfreight Terminal		CB	CB		
Wholesale Goods Establishment		P	P	P	
<b>OTHER</b>					
Alternative Energy Systems: Community Based	P	P	P	P	Subject to §14-306
Parking Lot (Principal Use)		P	P	P	Subject to §14-331
Parking Structure (Principal Use)		P	P	P	Subject to §14-331
Structures on Piers <sup>4</sup>	P	P			
Telecommunications Facility	P <sup>3</sup>	P <sup>3</sup>	P <sup>3</sup>	P <sup>3</sup>	Subject to §14-340
Utilities	P	P	P	P	Subject to §14-339
Wireless Communications Services	P	P	P	P	

**TABLE 12-1302 FOOTNOTES:**

P<sup>1</sup> Allowed only when secondary to developments of large office structures, research and development facilities, and/or manufacturing uses, and integrated into the larger development to serve the employees.

P<sup>2</sup> Subject to conformance with the Marina Master Plan.

P<sup>3</sup> Only wireless telecommunications antennas that comply with the stealth design standards of 14-339 (Wireless Telecommunications Antenna, Facility and Tower) are considered permitted uses.

P<sup>4</sup> Subject to conformance with State regulations for structures on piers.

<sup>6</sup>All uses that do not engage in alcoholic Beverage sales can continue to operate in the manner listed in the tables. Any use that does not engage in alcoholic beverage sales must obtain a conditional use unless that type of use is not allowed in that particular district.



**Table 15-405: Mount Vernon Neighborhood Height Map**

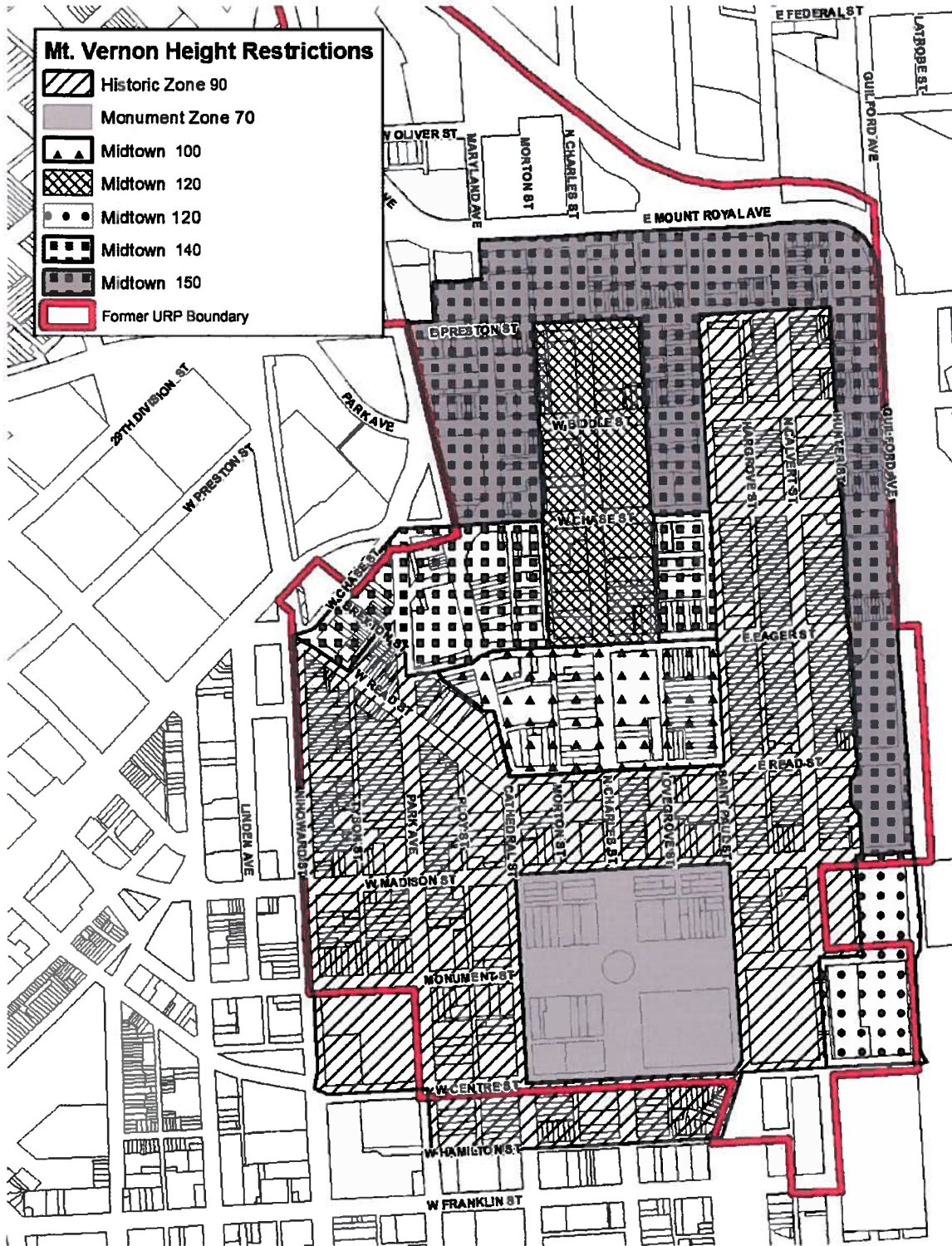





TABLE 15-601: PERMITTED ENCROACHMENTS

PERMITTED ENCROACHMENT	FRONT YARD, CORNER SIDE YARD	INTERIOR SIDE YARD	REAR YARD
Accessibility Ramps	X	X	X
Amateur (HAM) Radio Equipment (§15-502) – Not Including Tower Structures	X	X	X
Amateur (HAM) Radio Equipment (§15-502) – Tower Structures			X
Arbors or Trellises, attached to principal structure	X	X	X
Arbors or Trellises, freestanding			X
Awnings (Non-Sign Awnings), Sun Shades or Canopies (for a window, porch or door) - No more than 3' into a required yard	X	X	X
Chimneys - No more than 2' into a required yard	X	X	X
Compost Pile - Located in rear yard only & required to be within abin (open air composting prohibited) - 3' from any lot line			X
Cornices, Eaves, Belt Courses, Sills, 1-Story Bay Windows, and Similar Architectural Features - No more than 2' into a required yard	X	X	X
Deck or Balcony - No more than 5' from a front or corner side lot line	X	X	X
Exterior Stairwell - No more than 4' into a required yard			X
Fences and Walls - Limited to 3.5' in height in front & corner side yards - Limited to 6' in height in rear & interior side yards	X		
Fire Escapes	X – corner side yard only	X	X
Flagpoles	X	X	X
Garages, Detached (§15-506)			X
Greenhouses and Hoop-Houses (§15-507)			X
Laundry-Drying Equipment			X
Lawn Furniture (benches, sun dials, bird baths, etc.)	X	X	X
Mechanical Equipment (§15-509)	X	X	X
Ornamental Lighting (§15-505) - At least 5' from any lot line	X	X	X
Outdoor Fireplace			X
Playground Equipment and Playhouses	X – corner side yard only	X	X
Porches, Unenclosed, with or without roof (§15-512) - No more than 1 story in height - No more than 8' into a required yard	X	X	X
Rain Barrels and Above-Ground Cisterns	X	X	X
Recycling Collection Station (§15-514)			X
Refuse Disposal Dumpsters and Refuse Storage Areas (§15-515)		X	X



Satellite Dish Antenna, 1 meter or less in diameter (§15-516)	X	X	X
Satellite Dish Antenna, more than 1 meter in diameter (§15-516)		X - non-residential districts only	X
Solar Alternative Energy System – ground-mounted (§15- 517)	X	X	X
Steps, Open and Stoops	X	X	X
Storm Water Management Facilities	X	X	X
Swimming Pools			X
Tennis Courts			X
Terraces and Patios, open	X	X	X
Tool Houses, Sheds and Similar Structures for the Storage of Accessory Supplies			X
Wind Alternative Energy System (§15-519)			X



**Table 16-402: Off-Street Parking Dimensions**

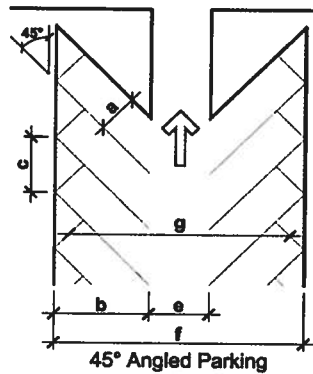
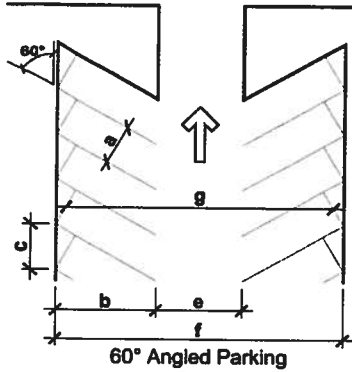
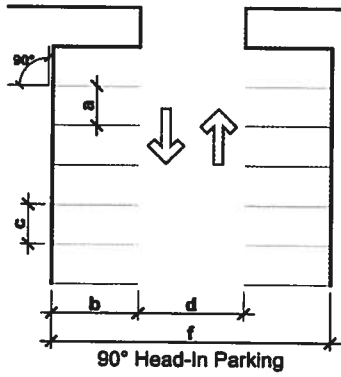
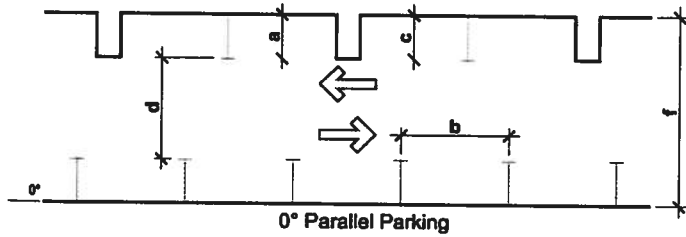

Parking Angle x°	MINIMUM DIMENSIONS						
	Stall Width	Stall Dept h	Skew Width (c)	Aisle Width	Aisle Width	Overall Module	Wheel Stop
	(a)	(b)		<i>Two-Way</i> (d)	<i>One-Way</i> (e)	(f)	(g)
0° (Parallel)	9	18'	9'	22'	11'	41'	.
90° (Head-In)	9'	18'	9'	22'	20'	58'	.
60°	9'	21'	9.8'	.	18'	60'	55.75'
45°	9'	19.8'	12'	.	12.5'	52'	46'



**TABLE 16-404B: DRIVEWAY STANDARDS**

<b>USES</b>	<b>RADIUS</b>	<b>MAXIMUM DRIVEWAY</b>
Residential for up to 5 spaces	10 feet	10 feet
Residential more than 5 spaces	10 feet	24 feet
Commercial, One-way	10 feet	18 feet
Commercial, Two-way	15 feet	36 feet
Industrial	30 feet	40 feet





**TABLE 16-406: REQUIRED OFF-STREET PARKING**

USES	PARKING
Adult Use	3 per 1,000sf GFA
Alternative Energy System	2 per 1,000sf of office area
Animal Hospital	1 per exam room
Art Gallery	1 per 1,000sf GFA
Arts Studio	1 per 2,000sf of studio area
Arts Studio - Industrial	1 per 2,000sf of studio area
Auditorium	1 per 10 persons of fire rated capacity
Bail Bond Establishment	2 per 1,000sf of GFA
Banquet Hall	1 per 10 persons of rated capacity
Boat Manufacturing, Repair and Sales	1 per 4 employees on maximum shift + 1 per company vehicle maintained on the premises
Body Art Establishment	1 per 1,000sf GFA
Broadcasting Station (TV or Radio)	1 per 2 employees on maximum shift + 1 per company vehicle maintained on the premises
Carry-Out Food Shop	2 per 1,000sf GFA + 3 stacking spaces per drive-through lane (where applicable)
Car Wash	2 per bay
Cemetery	2 per 1,000sf of office + 1 per 4 persons of fire rated capacity in chapel
Check Cashing Establishment	2 per 1,000sf of GFA
Community Center	1 per 10 persons of fire rate capacity
Contractor Storage Yard	2 per 1,000sf GFA of office and public use area
Convention Center	1 per 10 persons of rated capacity
Country Club	Cumulative: determined by uses within development (golf course, restaurant, etc.)
Cultural Facility	1 per 4,000sf of floor area
Day-Care Center: Adult or Child	1 per 4 employees on maximum shift
Driving Range	1.5 per tee stand
Dwelling: Above the Ground Floor	1 per dwelling unit
Dwelling: Caretaker's	1 per dwelling unit
Dwelling: Multi-Family	1 per dwelling unit
Dwelling: Multi-Family – Age-Restricted Housing	1 per 2 dwelling units
Dwelling, Rowhouse	1 per dwelling unit
Dwelling: Detached	1 per dwelling unit
Dwelling: Semi-Detached	1 per dwelling unit
Educational Facility: Primary and Secondary	1 per 4 teachers and employees + 1 per 50 students based on the greatest number of student enrollment permitted
Educational Facility: Post-Secondary	1 per 4 teachers and employees + 1 per 25 students based on the greatest number of student enrollment permitted
Educational Facility: Commercial-Vocational	1 per 4 teachers and employees + 1 per 25 students based on the greatest number of student enrollment permitted + 1 per facility vehicle if outdoor component is present such
Entertainment : Indoor	1 per 10 persons of rated capacity
<i>Movie Theater</i>	<i>1 per 4 seats for first 400 seats + 1 per 6 seats after first 400</i>
Entertainment : Live (Standalone)	1 per 10 of fire rated capacity
Financial Institution	2 per 1,000sf + 2 stacking spaces per drive-through lane
Food Processing: Light	1 per 4 employees on maximum shift or 1 per 1,000sf of GFA, whichever is less
Fraternity, Sorority House	When used for residence: 1 per 2 bedrooms
Freight Terminal	1 per 20,000sf GFA of warehouse space + 2 per 1,000sf of office space



**TABLE 16-406: REQUIRED OFF-STREET PARKING**

USES	PARKING
Funeral Home	2 per 1,000sf of office +1 per 4 fire rated capacity in chapel + 1 per company or business vehicle maintained on the premises
Gas Station	1 per 1,000sf GFA of accessory retail
Golf Course	3 per hole
Government Offices	2 per 1,000sf GFA
Government Facilities: Public Works	1 per 1,000sf of office area and public use area + 1 per government vehicle maintained on the premises
Greenhouse/Nursery	2 per 1,000sf GFA including outdoor sales and display area
Health Center	2 per 1,000sf of public use area
Heavy Retail, Rental or Service	1 per 4 employees on maximum shift or 1 per 1,000sf of GFA, whichever is less
Horse Stable	1 per 5 stalls
Hospital	1 per 10 hospital beds + 1 per 4 employees including staff doctors on maximum shift + 1 per 2 exam rooms in medical offices
Hotel/Motel	1 per 4 rooms
Industrial Boat Repair Facility	1 per 4 employees on maximum shift or 1 per 1,000sf of GFA, whichever is less
Industrial: General	1 per 4 employees on maximum shift or 1 per 1,000sf of GFA, whichever is less
Industrial: Light	1 per 4 employees on maximum shift or 1 per 1,000sf of GFA, whichever is less
Industrial: Maritime-Dependent	1 per 4 employees on maximum shift or 1 per 1,000sf of GFA, whichever is less
Kennel	2 per 1,000sf of public waiting area
Landfill: Industrial	1 per 4 employees on maximum shift or 1 per 1,000sf of office area, whichever is less
Live-Work Dwelling	1 per dwelling unit
Marina: Dry Storage	1 per 4 slips (During the off-season, September 15 to May 14, the parking area may be used for the storage of boats, trailers, or other related materials, as long as at least 10% of required parking remains)
Marina: Recreational	1 per 2 slips
Marina: Recreational Marina	1 per 2 slips
Marine Terminal	1 per 4 employees on maximum shift or 1 per 1,000sf of GFA, whichever is less
Materials Recovery Facility	1 per 4 employees on maximum shift or 1 per 1,000sf of office area, whichever is less
Medical/Dental Clinic	3 per 1000 sf GFA
Mini-Warehouse	1 per 50 storage units
Motor Vehicle Dealership	1 per 1,000sf GFA
Motor Vehicle Operation Facility	1 per 4 employees on maximum shift or 1 per 1,000sf of office area, whichever is less
Motor Vehicle Rental Establishment	2 per 1,000sf of public waiting & office area + 1 per company vehicle maintained on the premises
Motor Vehicle Service and Repair, Major or Minor	2 spaces per service bay
Movie Studio	1 per 4 employees on maximum shift or 1 per 1,000sf of office area, whichever is less
Office	1 per 800sf GFA
Outdoor Storage Yard	1 per 1,000sf GFA of office & public use area
Passenger Terminal	3 per 1,000sf GFA
Pawn Shop	2 per 1,000 GFA
Personal Services Establishment	2 per 1,000 GFA



**TABLE 16-406: REQUIRED OFF-STREET PARKING**

USE	PARKING REQUIREMENTS
Place of Worship	1 per 4 persons of rated capacity or 1 per 8 persons of fire rated capacity for place of worship whose worshipers are required to walk to worship because of religious tenant + parking required for additional uses on-site as per this table.
Printing Establishment	1 per 4 employees on maximum shift or 1 per 1,000sf of GFA, whichever is less
Racetrack	1 per 10 persons of rated capacity
Recreation: Outdoor	2 per 1,000sf of public use area – this does not include the actual play field or pool
Recreational Vehicle Dealership	1 per 1,000sf GFA
Research and Development	1 per 4 employees on maximum shift or 1 per 1,000sf of GFA, whichever is less
Residential Care Facility	1 per 4 employees on maximum shift plus 1 per 6 residents. However if the facility does not permit residents to have vehicles at the facility, the facility need not provide off street parking spaces for residents
Resource Recovery Facility	1 per 4 employees on maximum shift or 1 per 1,000sf of office area, whichever is less
Restaurant	1 per 100sf of indoor public seating area + 3 stacking spaces per drive-through lane (where applicable)
Retail Goods Establishment	2 per 1,000sf GFA
Rooming House	1 per 2 units
Shipyards	1 per 4 employees on maximum shift or 1 per 1,000sf of GFA, whichever is less
Lodge or Social Club	1 per 10 persons of rated capacity
Stadium	1 per 10 persons of rated capacity
Tavern	1 per 100sf of indoor public seating area
Transfer Station/Refuse Collection Facility	1 per 4 employees on maximum shift or 1 per 1,000sf of office area, whichever is less
Truck Repair	2 truck-sized parking space per service bay + 1 per 4 employees on maximum shift
Truck Stop	1 truck-sized parking space per 5,000sf of site area + 1 per 4 employees on maximum shift
Truck Terminal	1 per 4 employees on maximum shift or 1 per 1,000sf of office area, whichever is less
Warehouse	1 per 20,000sf GFA of warehouse space + 2 per 1,000sf of office space
Waterfreight Terminal	1 per 4 employees on maximum shift or 1 per 1,000sf of GFA, whichever is less
Wholesale Goods Establishment	1 per 4 employees on maximum shift or 1 per 1,000sf of GFA, whichever is less
Video Lottery Facility	1 per 10 persons of fire rated capacity



**TABLE 16-501: COLLECTIVE PARKING CALCULATION**

LAND USE	Weekday			Weekend		
	Mid-7am	7am-6pm	6pm-Mid	Mid-7am	7am-6pm	6pm-Mid
<b>Residential</b>	100%	55%	85%	100%	65%	75%
<b>Commercial</b>	0%	100%	80%	0%	100%	60%
<b>Restaurant</b>	50%	70%	100%	45%	70%	100%
<b>Hotel/Motel</b>	100%	50%	90%	100%	65%	80%
<b>Movie Theater</b>	0%	70%	100%	5%	70%	100%
<b>Office</b>	5%	100%	5%	0%	40%	10%
<b>Industrial</b>	5%	100%	5%	0%	60%	10%





TABLE 16-705: REQUIRED BICYCLE SPACES

USES	LONG-TERM SPACES	SHORT-TERM
Auditorium or Recreation/Entertainment: Indoor	1 per 150 persons at rated capacity	None
Banquet Hall	1 per 200 persons at rated capacity	None
Cemetery	1 per 10,000sf of office and chapel space	1 per 7,500sf of office and chapel space
Convention Center	1 per 20,000sf GFA	1 per 40,000sf GFA
Cultural Facility	1 per 10,000sf GFA	1 per 10,000sf GFA
Day Care or Rehabilitation Center	1 per 10,000sf GFA	None
Educational Facilities: Primary and Secondary	1 per 20 teachers and employees + 1 per 50 students based on greatest number of student enrollment permitted	None
Educational Facilities: Post-Secondary, Commercial- Vocational	1 per 20 teachers and employees + 1 per 25 students based on greatest number of student enrollment permitted	None
Government Facilities: Public Works	1 per 8,000sf GFA	1 per 15,000sf GFA
Hospital or Medical/Dental Center	1 per 50,000sf GFA	1 per 30,000sf GFA
Lodging: Hotel, or Bed and Breakfast	1 per 8 dwelling units	None
Outdoor: Recreation/Entertainment	1 per 15,000sf of public use area	1 per 5,000sf of public use
Industrial: General	1 per 30,000sf GFA	None
Residential Care Facility	1 per 8 dwelling units	1 per 16 dwelling units
Movie or Arts Studio or Art Gallery	1 per 10,000sf GFA	1 per 5,000sf GFA
Multi-Family Dwelling (Age-restricted housing may reduce required bicycle parking to 75% of requirement)	1 per 4 dwelling units	1 per 12 dwelling units
Office or Financial Institution	1 per 10,000sf GFA	1 per 25,000sf GFA
Parking Lot or Structure (Principal Use)	1 per 20 vehicle parking spaces	None
Parks and Playgrounds or Open Space	None	Per Director of Planning
Passenger Terminal	Per Director of Planning review	Per Director of Planning
Place of Worship	1 per 15,000sf GFA	1 per 7,500sf GFA
Restaurant or Tavern/Bar	1 per 4,000sf GFA	1 per 4,000sf GFA
Retail Goods Establishment, Personal Services Establishment or other Business open to the	1 per 10,000sf GFA	1 per 5,000sf GFA
Shopping Center	1 per 7,500sf of gross leasable area	1 per 10,000sf of gross leasable
Stadium	1 per 200 seats	None



**TABLE 16-902: OFF-STREET LOADING REQUIREMENTS**

USES	NUMBER OF SPACES REQUIRED
<b>Commercial &amp; Institutional Uses</b>	
20,000 - 100,000sf of gross floor area	1 loading space
Over 100,000sf of gross floor area	2 loading space
<b>Industrial Uses</b>	
5,000 - 10,000sf of gross floor area	1 loading space
10,001 - 40,000sf of gross floor area	2 loading spaces
40,001 - 100,000sf of gross floor area	3 loading spaces
For each additional 100,000sf of gross floor area	1 loading space



TABLE 17-804: FREESTANDING SIGN REGULATIONS

DISTRICTS	MONUMENT SIGN		POLE SIGN	
	MAXIMUM SIGN AREA	MAXIMUM SIGN HEIGHT	MAXIMUM SIGN AREA	MAXIMUM SIGN HEIGHT
R-1A through R-10	32sf	6'	Prohibited	Prohibited
C-1, C-1-VC	32sf	6'	Prohibited	Prohibited
C-1-E	32sf	6'	Prohibited	Prohibited
C-2	32sf	6'	24sf	16'
C-3	50sf	8'	32sf	20'
C-4	50sf	8'	32sf	20'
C-5	50sf	8'	Prohibited	Prohibited
OIC	50sf	8'	50sf	24'
BSC	50sf	8'	50sf	24'
I-MU	50sf	8'	50sf	24'
I-1	50sf	8'	50sf	24'
I-2	50sf	8'	50sf	24'
M-1	50sf	8'	50sf	24'
EC-1 or EC-2	50sf	8'	32sf	20'
H	50sf	8'	32sf	20'
OR	32sf	6'	Prohibited	Prohibited
TOD-1,-2,-3,-4	32sf	6'	Prohibited	Prohibited



TABLE 17-812: PROJECTING SIGN REGULATIONS		
DISTRICTS	MAXIMUM SIGN AREA	
	Ground Floor	2 <sup>nd</sup> Floor
R-1A through R-10	Prohibited	Prohibited
C-1, C-1-VC	12sf	6sf
C-1-E	12sf	6sf
C-2	16sf	8sf
C-3	24sf	12sf
C-4	24sf	12sf
C-5	36sf	12sf
OIC	48sf	Prohibited
BSC	48sf	Prohibited
I-MU	48sf	Prohibited
I-1	48sf	Prohibited
I-2	48sf	Prohibited
MI	48sf	Prohibited
EC-1	Prohibited	Prohibited
EC-2	36sf	12sf
H	36sf	12sf
OR	Prohibited	Prohibited
TOD-1,-2,-3,-4	16sf	8sf

